

Service Experience 2006, ME and MC Engines

Contents:

Introduction

The ME/ME-C Engine Series

- The ME concept
- Hydraulic cylinder unit
- Hydraulic power supply
- Engine Control System
- Alpha Lubrication system
- ME engine service experience – summary

The MC/MC-C Engine Series

- Time Between Overhaul for the latest generation of MC engines
- Scuffing investigation
- Bearings
- Cracks in the camshaft housing for K98 engines

Concluding Remarks

Service Experience 2006, ME and MC Engines

Introduction

The introduction of the electronically controlled camshaft-less low speed diesel engines is proceeding rapidly with many ME engines ordered and, consequently, many ME engines entering service. At the time of writing, more than 250 ME engines are on order or have been delivered. This number proves the market's acceptance of this technology. Of the ME engines, 50 are in service, and they range from the L42ME engine up to the K98ME/ME-C engines. An example is shown in Fig. 1.

Although the ME technology may seem brand new to many in the industry, MAN B&W Diesel has been devoted to the development of electronically controlled low speed diesels for a long time, actually since the early 1990s. The first engine featuring the ME technology was a 6L60MC/ME, the name indicating that it was originally built as a conventional MC engine with camshaft, and then later rebuilt into an ME engine. The ME version of this engine has now logged about 30,000 running hours and it has, throughout this period, been used to fine-tune the ME technology.

The main objectives for the ME-technology are:

1. Improved fuel economy at all load point, Fig. 2
2. Flexibility with respect to present as well as future emission requirements, Fig. 3
3. Easy engine balancing/adjustability, Fig. 4
4. System integration (example, Fig. 5: Alpha Lubricator fully integrated in the ME-system)
5. Smokeless operation
6. Stable running of very low load



Fig. 1: General view, 12K98ME installed in a container ship

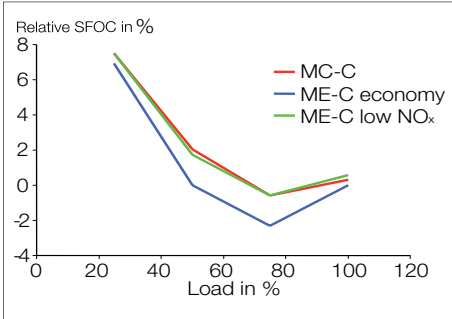

All these objectives have been accomplished to a very satisfactory level on the first ME engines in service, fig.6. Future updates and fine tuning with new releases of the control software further enhance advantages of the ME concept.

Other ME features realized are:

- Real camless operation with either engine driven or electrically driven standard industrial pumps for the hydraulic power supply
- Standard flexibility with respect to changing between HFO and MDO operation
- Simplicity is kept by low number of components (e.g. only one NC valve per cylinder)
- Furthermore the number of assembly points are kept low by having only one high pressure oil system
- Cylinder control computers are kept away from areas with high heat exposure in order to limit thermal heating
- Apart from the ME-specific features like OROS combustion chamber with slide fuel valves, nimonic exhaust valves with W-seat securing long time between overhaul and very satisfactory cylinder condition.

Fig. 2: Improve fuel economy at all load point

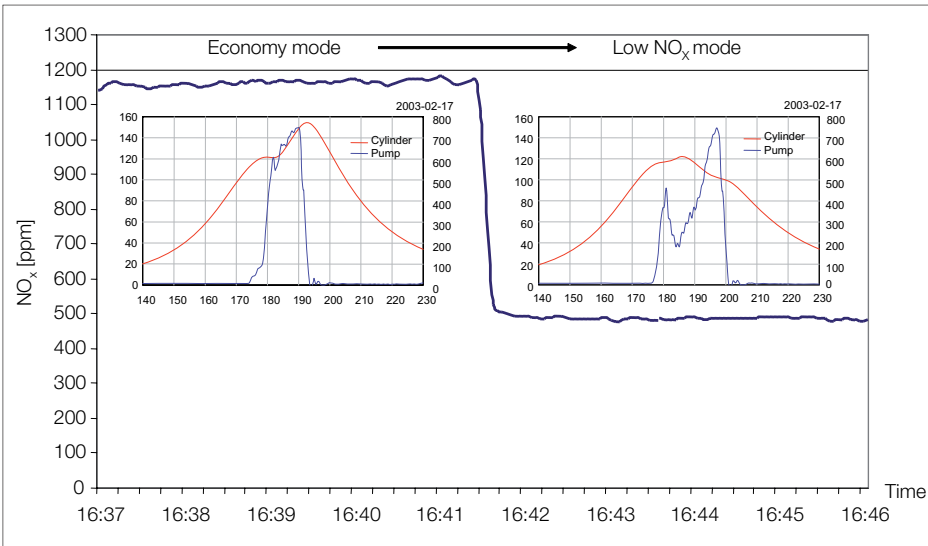

Fig. 3: Flexibility with respect to emission

Adjustment of p_{max} & MIP

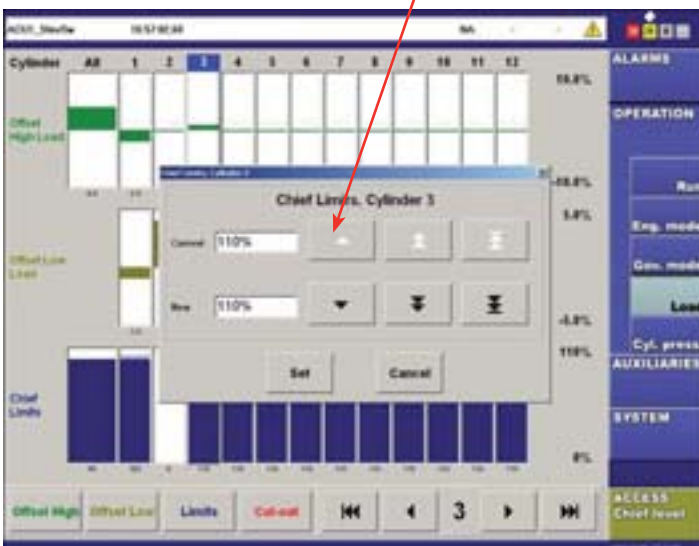

Fig. 4: Easy engine balancing/adjustability



Fig. 5A: System integration example: Alpha Lubricator

The ME/ME-C Engine Series

The ME concept

The ME engine concept consists of a servo-hydraulic system for activation of the fuel oil injection and the exhaust valves. The actuators are electronically controlled by a number of control units forming the 'engine control system', see Fig. 7.

The fuel injection is accomplished by pressure boosters which are mechanically simpler than the fuel pumps on conventional MC engines. The fuel plunger on the ME engine is driven by a piston actuated with pressurised control oil from an electronically controlled proportional valve as the power source. Also, the exhaust valve is opened hydraulically and closed by an air spring, as on the MC engine. Similar to the fuel injection pressure booster, the electronically controlled exhaust valve actuator is driven by the pressurised control oil which, for the exhaust valve, is fed through an on/off type control valve or a proportional type control valve.

In the hydraulic loop, see Fig. 8, lubricating oil is used as the medium. It is filtered through a fine filter and pressurised by a hydraulic power supply unit mounted on the engine. A separate hydraulic oil system is optional. Furthermore, separate electrically driven main pumps are optional.

From the hydraulic power supply unit, the generated servo oil is fed through double-wall piping to the hydraulic cylinder units, see Fig. 9. There is one such unit per cylinder. Each unit consists of a fuel oil pressure booster and an exhaust valve actuator. A Fuel Injection and Valve Actuation (FIVA) control valve is mounted on the HCU. On early ME engines Electronic Valve Fuel Injection (ELFI) and Electronic Valve Actuation (ELVA) control valves are mounted

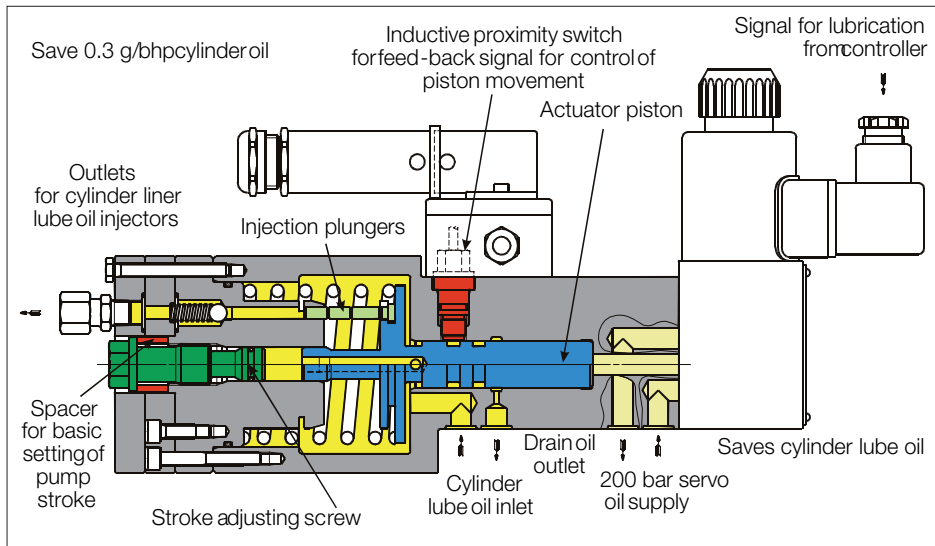

Fig. 5b: System integration example: Alpha Lubricator

Type	In Service
K98ME	3
K98ME-C	4
S90ME-C	2
S70ME-C	12
L70ME-C	3
S60ME-C	16
L60ME	1
S50ME-C	8
L42ME/MC	1
Total	50
More than 250 engines on order/delivered	

Fig. 6: ME/ME-C list of references

This paper will describe the service experience obtained with the commercial ME and ME-C engines in service.

For the MC/MC-C engine series, the feedback from service has over the last 4-5 years resulted in an extension of the Time Between Overhauls (TBO). We have not yet fully experienced the benefits of this development. However, the latest feedback from service indi-

cates that 5 years between major overhauls are looking to be realistic. It will be discussed how this development can benefit different operators. Also the development in relation to the cylinder condition with focus on cylinder oil consumption will be touched on.

The latest feedback from service in relation to bearings will also be outlined, as well as the cracks in the camshaft housing structure of the K98 engines will be described and solutions will be shown.

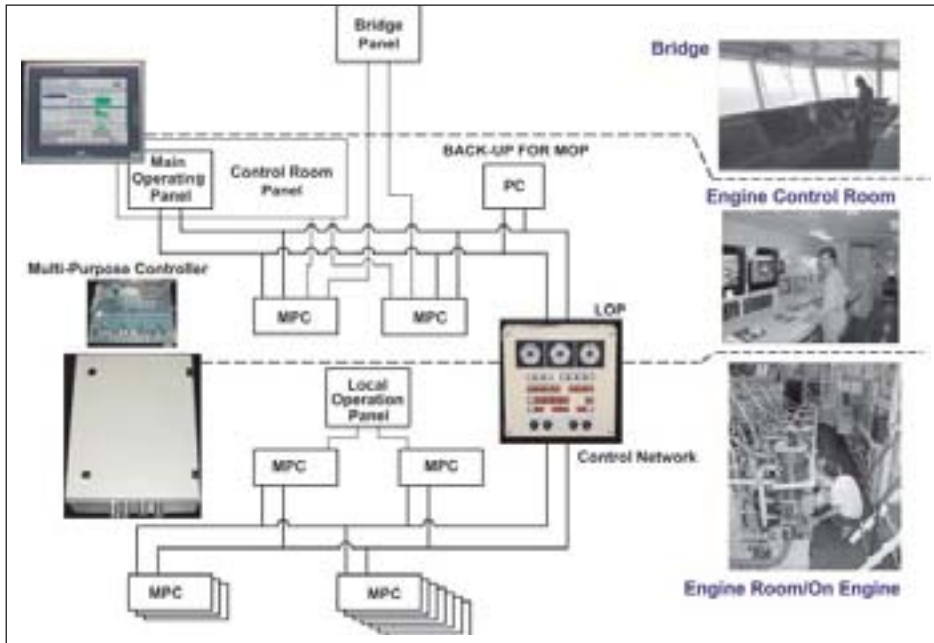

Fig. 7: Engine Control System (ECS)

on the HCU. Also the Alpha Lubricator is mounted on the HCU.

It should be realised that even though an ME engine is simple to operate, training of crews in the ME technology is important in order to ease the understanding and avoid any confusion and anxiety that could otherwise occur. To facilitate this, MAN B&W Diesel has set up an ME training centre including a complete ME simulator, so that crews can get hands-on training at our works in Copenhagen. Fig. 10 shows the ME simulator in Copenhagen. Mobile versions of such ME simulators are presently being built in order to be able to train crews and customers at other locations than Copenhagen.

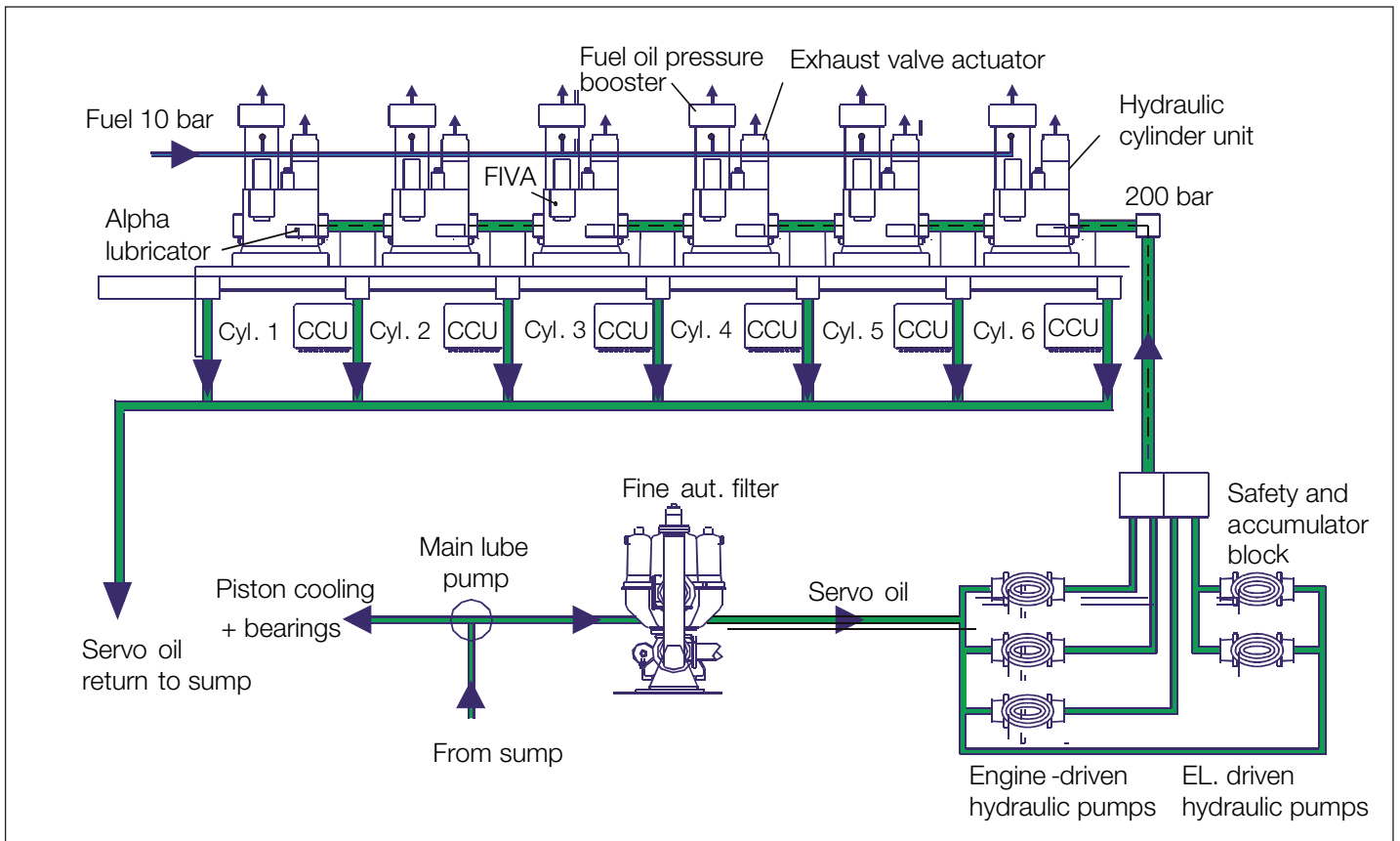

Fig. 8: Hydraulic loop of the ME engines

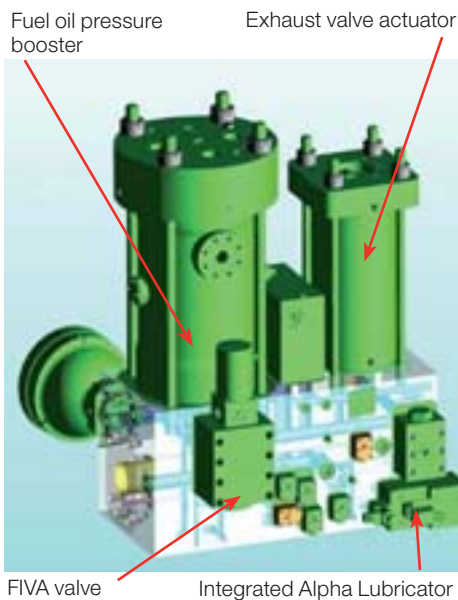

Fig. 9: Hydraulic Cylinder Unit (HCU)

In general, operators have reported, and thus confirmed, the expected benefits of the ME technology, such as lower FOC (Fuel Oil Consumption), better balance between cylinders, better acceleration characteristics and improved dead slow performance. Also, the detailed monitoring and diagnostics of the ME engine provide easier operation and longer times between overhauls, and indeed the ME technology makes it much easier to adjust the Mean Indicated Pressure (MIP) and p_{max} . This is carried out via the Main Operating Panel (MOP) in the control room, ref. Fig. 7.

Operators have also found that when operating in rough weather, there is less fluctuation in engine rpm com-

pared to an engine with camshaft-driven fuel injection. Importantly, owners of ME engines in service for at longer period of time report savings in fuel oil consumption in the range of up to 4%, when comparing to a series of sister vessels, having the camshaft equipped counterpart type of engines. Apart from the inherent better part load fuel oil consumption of an ME engine, one reason for the reported improved fuel consumption figures is that the ME engine makes it very easy to always maintain correct performance parameters.

Fig. 11 demonstrates the cylinder condition on the first 7S50ME-C after 10,717 running hours, and the condition is perfect. As regards the cylinder condition, in particular, observations



Fig. 10: ME Training Centre with complete ME simulator



Fig. 12: 12K98ME, port inspection shows excellent condition



Fig. 11: 7S50ME-C, cylinder condition after 10,717 running hours



Fig. 13: 12K98ME, crosshead bearing and main bearing

so far indicate that we can expect an improved cylinder condition in general, probably owing to the fact that the fuel injection at low load is significantly improved, compared to conventional engines.

Also other engines have been closely followed up with a view not only to ME related parts, but also to check the condition of 'ordinary' components and areas of interest. Figs. 12 and 13 show pictures taken on the first 12K98ME engine.

Hydraulic cylinder unit

The hydraulic cylinder unit, of which there is one per cylinder, consists of a hydraulic oil distributor block with pressure accumulators, an exhaust valve actuator with ELVA control valve and a fuel oil pressure booster with ELFI control valve. Each individual HCU is interconnected by double-wall piping, through which the hydraulic oil is led. After delivery of the first 20 ME engines, the ELVA and ELFI valves were substituted by one common FIVA valve con-

trolling both the exhaust valve actuation and the fuel oil injection.

ELFI valves

On the Print Circuit Board (PCB) components have come loose due to vibrations. Fig. 14 shows a DC-DC converter which has come off. Improvements by means of resilient mountings have been introduced on all vessels in service with ELFI valves, and performance has been good hereafter, see Fig. 15 .

ELVA valves

Early service experience proved that low ambient temperatures, as often experienced during shop tests in the winter season, gave rise to sticking high-response valve spools in the ELVA valve due to low hydraulic oil temperatures. The diameter of the spool was reduced in order to obtain correct functioning of the high-response valve as shown in Fig. 16.



Fig. 14: ELFI valve, DC-DC converter coming off due to vibration of PCB

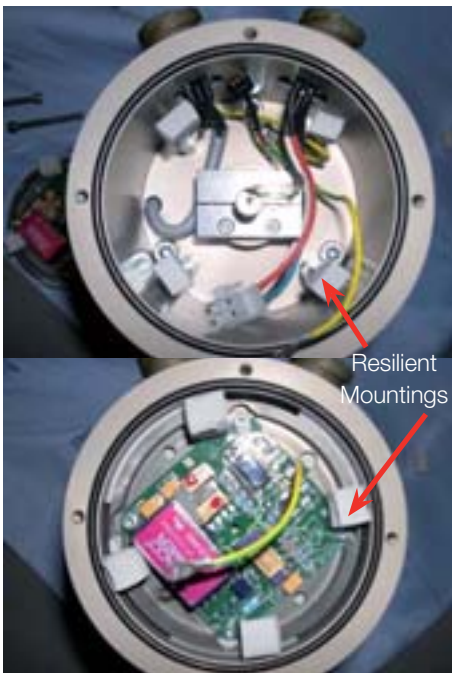

Fig. 15: ELFI valve, PCB secured by resilient mountings

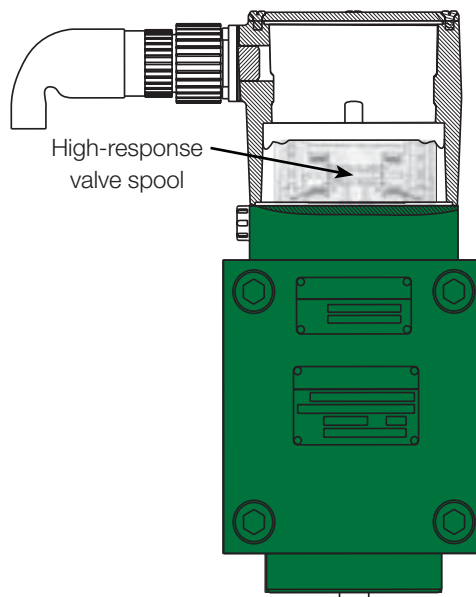

Fig. 16: ELVA valve, location of high-response valve spool





Fig. 17: ELVA valve, sticking high- response valve spool

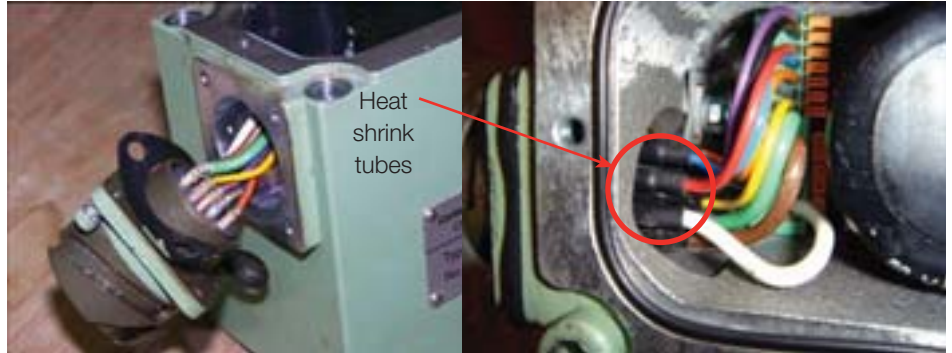

Fig. 19: ELVA valve, reinforcement by heat shrink tubes

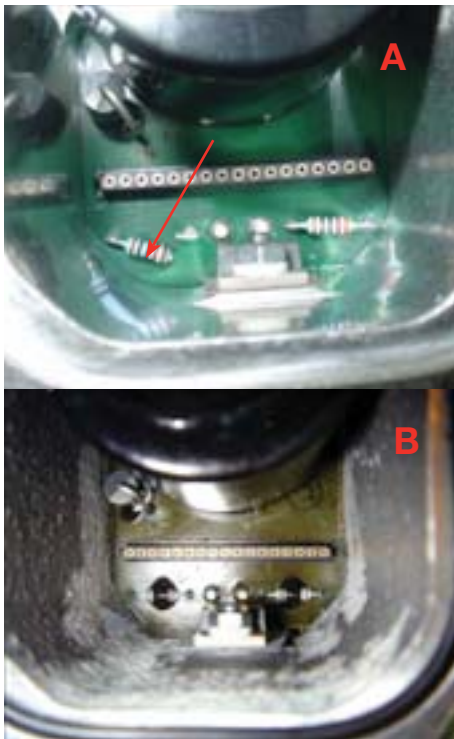

Fig. 18: ELVA valve,
A: resistor broken due to vibrations
B: damping secured with silicon glue

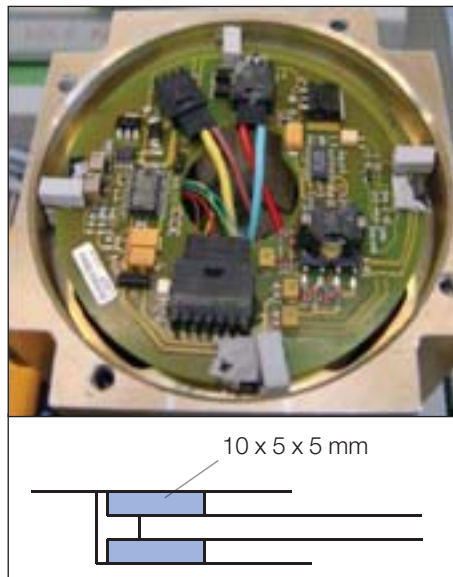

Fig. 20: FIVA valve, resilient mounting of PCB

pin is reinforced by a heat shrink tube, Fig. 19.

FIVA valves

In general, the FIVA valves have seen much fewer vibration-related troubles than the ELFI and ELVA valves. A resilient mounting design, Fig. 20, has been applied from the beginning and an extended vibration testing (up to 1 kHz) has been used, Fig. 21.

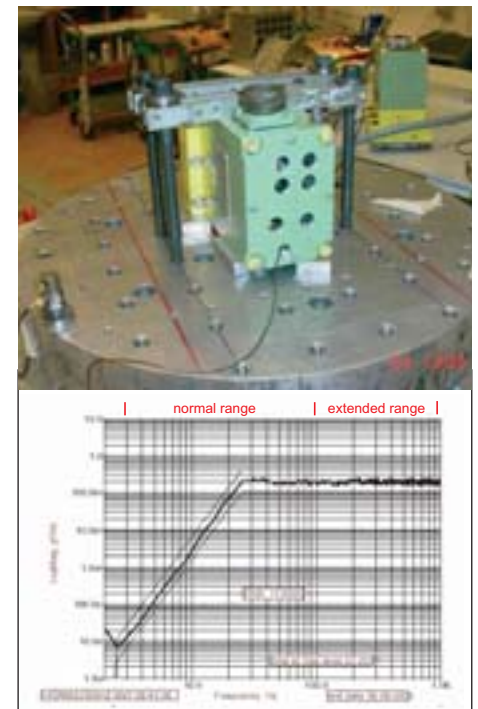

Fig. 21: Control valve, extended vibration testing

However, a quality problem with too small clearances between the spool and the housing in the high-response valve has been encountered in service. This has led to a sticking spool, Fig. 17. In such a case the control system encounters improper lifting of the exhaust valve and fuel is, as a consequence, stopped to the unit in question. Engine

running in one-cylinder misfiring is then experienced. A change of ELVA valves to 100% quality controlled units has taken place.

Also on the ELVA valves, we have seen components breaking off due to vibrations, like the resistor shown in Fig. 18. The fix has been to apply silicon glue as damping media.

Wires breaking in the crimpings in the connector because of vibrations have also been experienced. The connection between the wire and the connector

In a few cases, we have seen growth of the main spool in the FIVA valve. Fig. 22 shows a main spool where the diameter has grown 6 micron. The reason has been put down to improper heat treatment of the main spool and the process has been corrected.

Feedback sensors for exhaust valve and fuel oil booster

The sensor signal was out of range in one end of the exhaust valve stroke on certain engines, which resulted in a signal failure alarm. This was caused by incompatibility between the sensitivity of the sensor and the material of the cone on the exhaust valve. The calibration of the sensor has been changed.

The plastic sensor tip has broken loose or it has been pressed in, Fig. 23. The tip has been reinforced and the internal moulding in the tip has been improved by process improvements.

Double-wall pipes

Problems with hydraulic oil leakages have been seen during shop tests on the largest engines because of seal damage. The main reason for these problems was lack of quality from a new sub-supplier of these sealings. In any case, it was decided to upgrade the seal design for the 80-98 bore engines, see Figs. 24 and 25.

In the new design, the sealing function and the function of carrying the weight

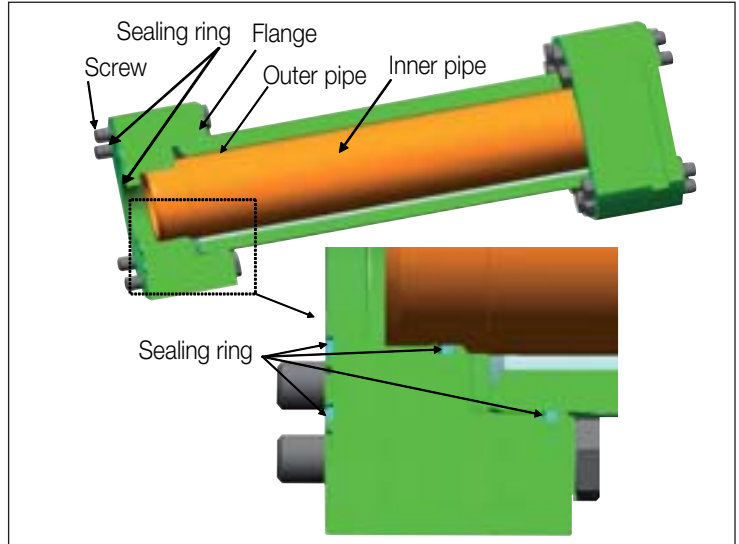

Fig. 24: Double-wall piping, old sealing arrangement

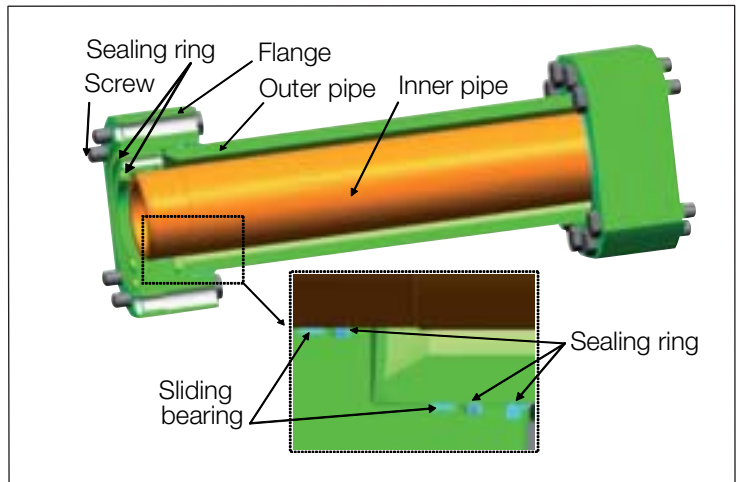

Fig. 25: Double-wall piping, new sealing arrangement



Fig. 22: FIVA valve, growth of main spool

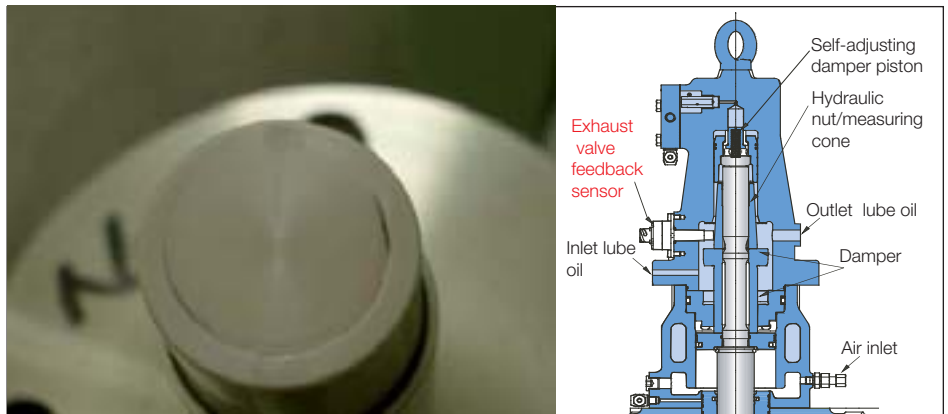
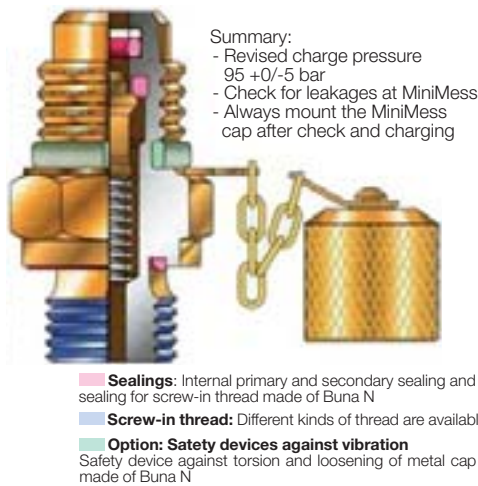
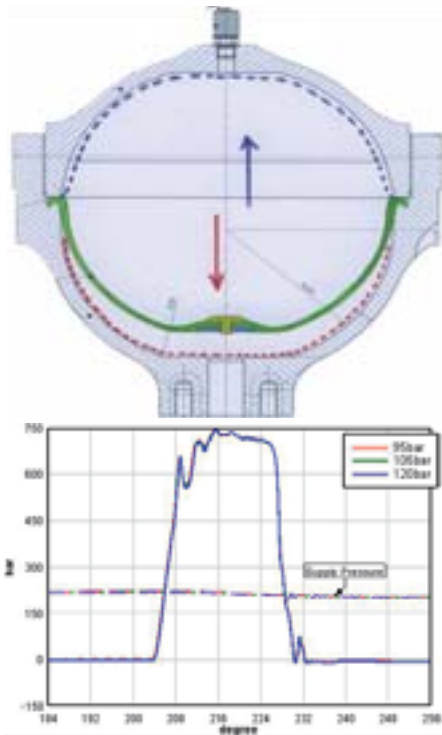

Fig. 23: Exhaust valve feedback sensor



MiniMess cap after check and charging. Furthermore, it is recommended to check the nitrogen pressure with six months intervals.

Hydraulic power supply

The hydraulic power supply unit produces the hydraulic power for the hydraulic cylinder units. The hydraulic power supply unit includes both the engine-driven pumps, which supply oil during engine running, and the electrically driven pumps, which maintain the system pressure when the engine is at a standstill. The engine-driven pumps are coupled through a gear drive or a chain drive to the crankshaft, and are of the electronically controlled variable displacement type.

The hydraulic power supply system, Fig. 27, features, as standard, a number of engine-driven pumps and electrically driven start-up pumps. The engine-driven pumps are axial piston pumps (swash plate types), and the flow is controlled by a proportional valve. On some K98 engines, we have initially seen problems with noise from these pumps during astern operation. As a preliminary countermeasure, this has effectively been cured by installing booster pumps securing that cavitations on the suction side of the swash

Fig. 26: Maintenance of accumulators

of the piping and hydraulic oil have been divided. The sealing function is now taken care of by the U-cup sealings and the carrying function by the guiding tapes. Furthermore, a scraper ring has been introduced in order to ensure reliable performance of the outer sealing. Additional lubrication of the sealings is permanently present by the low pressurisation of the outer pipe.

Maintenance of accumulators

Regarding accumulators, we have seen cases of damage to the diaphragms inside the accumulators. Maintenance of accumulators was the subject of the first dedicated Service Letter for ME engines. Fig. 26 summarises our recommendations, which are to adjust the nitrogen pressure to 95 bar, check MiniMess for leakages and apply the

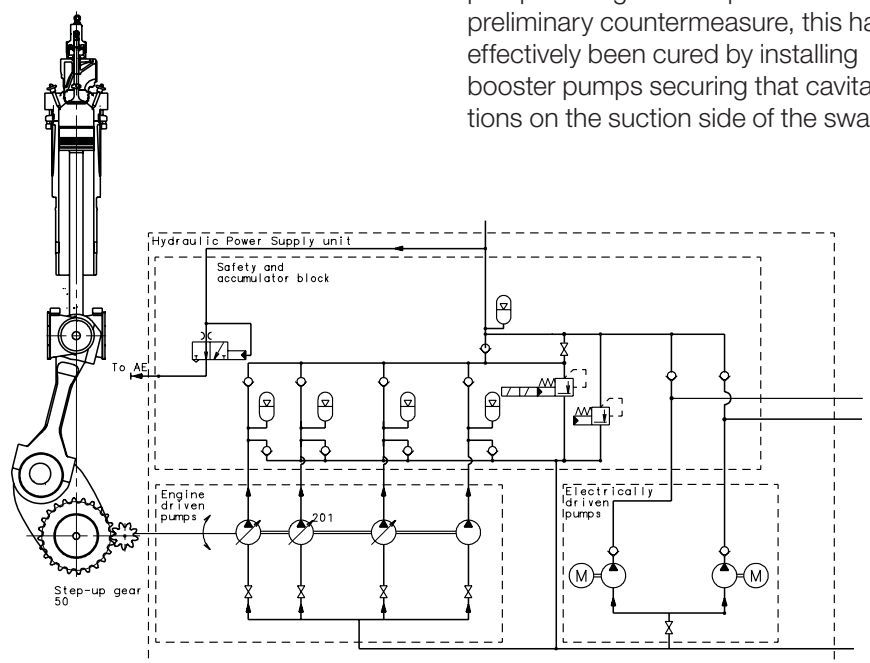

Fig. 27: Hydraulic power supply diagram



Fig. 28: Flexible hoses on K98

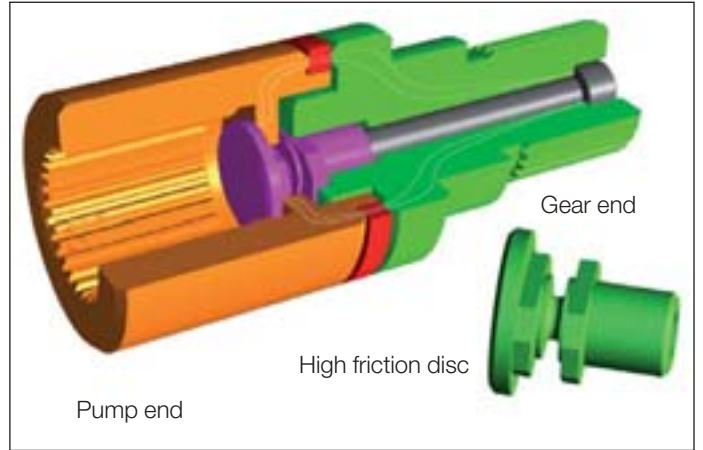

Fig. 31: Pump safety shaft, new shaft assembly with central bolt

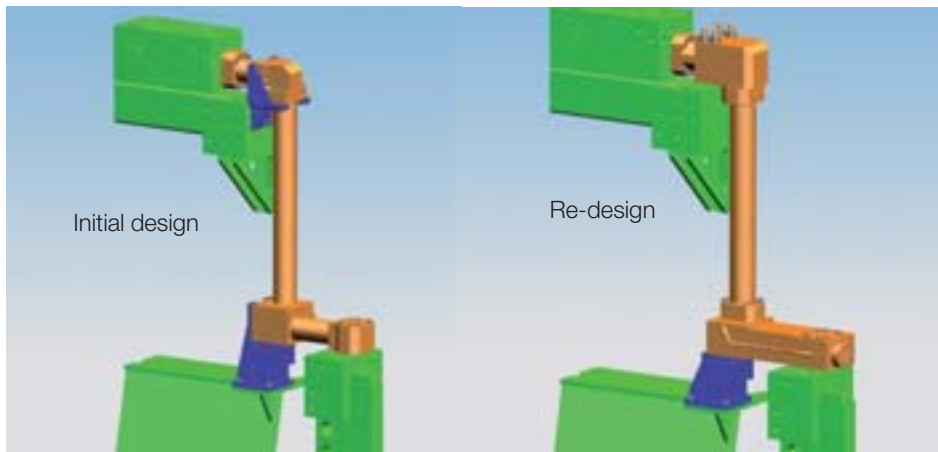

Fig. 29: Double-wall piping re-design on 6S90ME-C

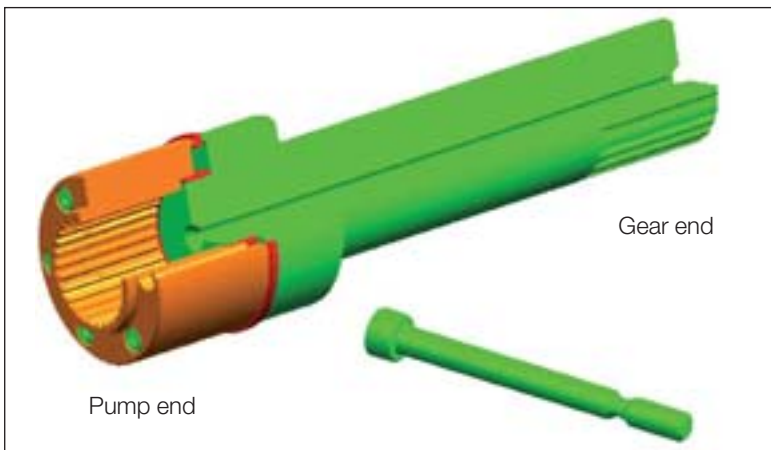

Fig. 30: Pump safety shaft, initial design

plate pumps will not occur during astern running. A permanent counter-measure has been to equip the largest engines (e.g. 12K98ME/ME-C) with more swash plate pumps of a smaller size. These smaller-size pumps do not have problems with astern operation.

For certain engine types, start-up pump capacities have been increased to be able to deliver sufficient start-up pressure on one start-up pump within 90 seconds.

On new engines, the hydraulic oil filter has been re-specified from mess size 10 micron to mess size 6 micron. The reason for this has been to prolong the lifetime for various components subjected to wear.

Hydraulic pipes

Cases of cracked hydraulic pipes for the servo oil to the swash plate pumps have been seen, and investigations have proved these cracks to occur due to vibrations. To avoid this, the pipe dimension has been changed and flexible hoses have been introduced as an extra precaution, see Fig. 28.

On the 6S90ME-C engine, the double-wall piping connecting the aftmost



Fig. 32: 7S50ME-C, gearbox for engine-driven hydraulic pumps

shown in Fig. 30 featured six studs and a frictional connection, and the bolts were sheared at a too low torque.

The new design shown in Fig. 31 has a centre bolt which tightens together a frictional connection. No problems have been experienced with this design.

Besides this, we have introduced forced lubrication of the shaft assembly to counteract cases of wear of the splines for the shaft and gear wheel. Splines are now also hardened.

Gearbox

Fig. 32 shows an example of an inspection of the gearbox for the pump drive after 3,000 hours. The condition of the gearbox was found to be excellent. The only modification introduced is a tip relief on the teeth in order to prevent initial running in marks.

Engine Control System

MPC boards

The ME Engine Control System (ECS) consists of a set of Multi Purpose Controllers (MPCs). These are generally used in Auxiliary Control Units (ACU), Cylinder Control Units (CCU), Engine Control Units (ECU) and Engine Interface Control Units (EICU), and they are identical from a hardware point of view. Once connected in the individual application (CCU, ACU, ECU or EICU), the MPC will load software according to the functionality required.

On the MPC, channels 70 and 71 have been damaged in some cases. This was caused by wrong or fluctuating signals at the outputs. Consequently, a breakdown of a capacitor in the DC-DC converters (Fig. 33) took place. This was determined to happen when 24V or higher voltages (noise, etc.) were applied backwards into the terminals

HCU and the HPS has been redesigned, Fig. 29. Disintegration of the horizontal parts at the HCU and HPS was experienced at a shop test when the outer pipe was pressurised. Rectification was carried out and verified during the shop test on the first 6S90ME-C engine.

Shafts for engine-driven hydraulic pumps

Initially, teething problems have included breakage of the shafts for the engine-driven hydraulic pumps.

The purpose of the shaft design is to set an upper limit to the transferred torque, so as to safeguard the common gear in the event of damage to a pump. However, the shafts broke due to a too low torque capability.

The design of the shafts has been changed in order to increase the margin against breakage. The initial design

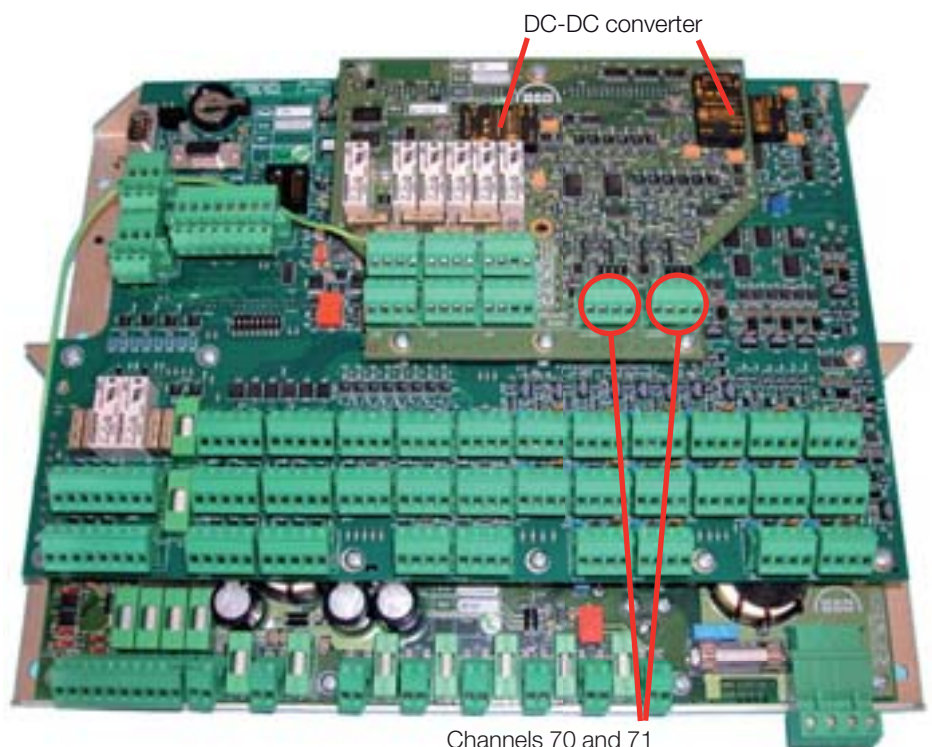

Fig. 33: MPC board, failure of channels 70 and 71

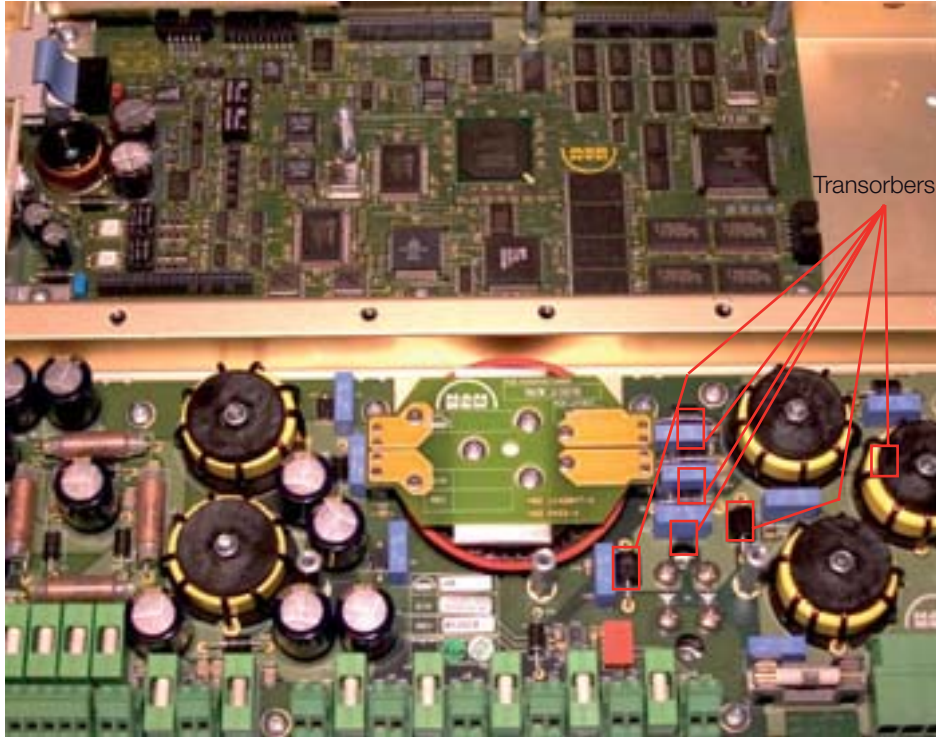

Fig. 34: MPC board (Power Filter Board) isolation failure

We have experienced bend pins in the PCB to PCB connectors. This is a production failure, and additional production tests have been added on the fully assembled units to sort out erroneous units for repair.

A general problem has been that loose, unused screws in terminals on PCBs mounted on the engine are worn by vibrations, thereby causing emission of metallic dust in the area near the terminal involving a risk of causing short circuit, Fig. 36. Instructions have been released requiring that all screws, also unused, must be tightened with at torque screwdriver.

Main Operating Panels (MOPs)

The present execution of the ME engine control system comprises one Main Operating Panel (MOP) which is an industrial type PC with an integrated

of the channels. Initially, the AO-DO Daughter boards of the MPCs in production were improved by applying a transorb across the output terminals. Later, the board has been redesigned.

Due to inferior quality of a component (a transorb) used in the power filter board of the MPC, Fig. 34, isolation failures were experienced. Certain situations caused too high 'leak-currents' through the transorbors. Manufacturers of the transorbors have been black-listed and transorbors from reliable manufacturers have been applied.

Production failures in the Printed Circuit Boards (PCBs) have caused broken connections in the inner layers, Fig. 35. The PCB base material has been changed to a type with a lower thermal expansion coefficient in the cross-sectional direction. Furthermore, the copper layer thickness in plated-through holes has been increased to fulfil the specification.

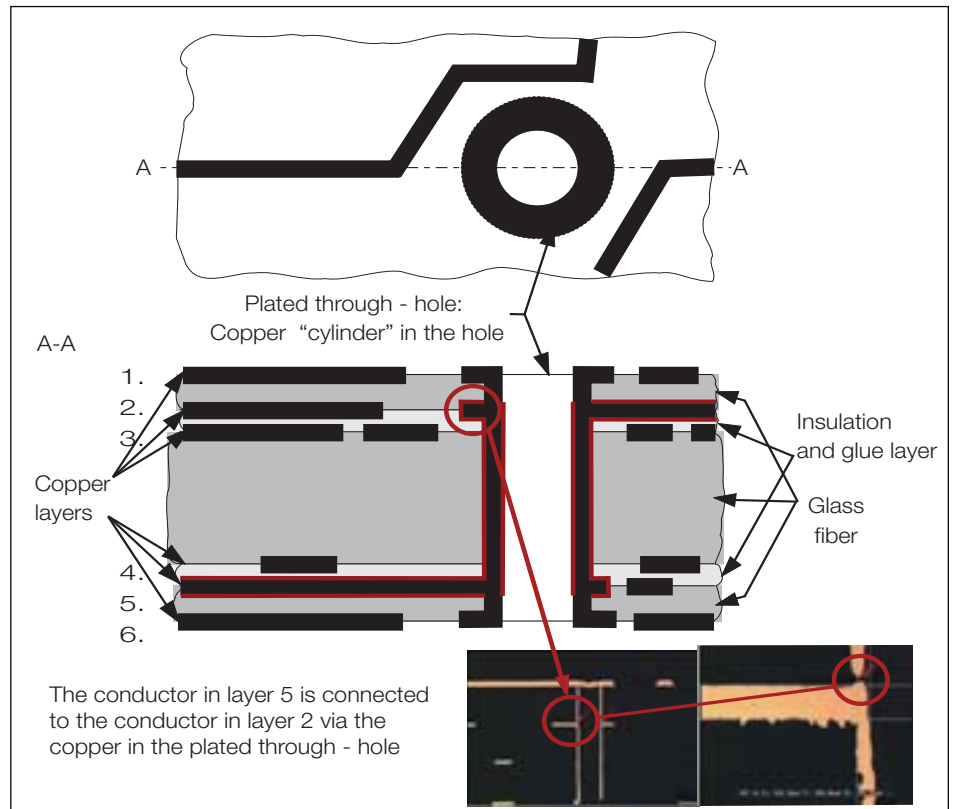

Fig. 35: PCB, broken copper layers



Fig. 36: PCB, metallic dust from untightened (unused) screws

touch screen from where the engineer can carry out engine commands, adjust engine parameters, select the engine running modes and observe the status of the control system. In addition to this, the system comprises also a conventional marine approved PC serving as a back-up unit for the MOP.

Both PCs are delivered with their own customised PC type specific operation system image software pre-installed. At the time of installation and prior to test and commissioning, both PCs are loaded with the same application software and the same plant specific parameter software.

Because of the use of conventional PC types for the back-up unit, we experience very frequent model changes to this unit. In connection with the introduction of a new model, it is necessary to prepare new software images together with updating of documentation. This creates a lot of logistical issues.

In order to ease the handling, installation and support on plants in service for the licensor, licensee, shipyard and owner, we will introduce the same hardware for the back-up unit as for the Main Operating Panel. The PC type will remain unchanged for a longer period as it comprises a chipset with an extended product life support (Intel Industrial PC platform solutions). The solution will comprise a separate PC with a separate touch screen display. This solution will be more flexible and meet various specific requirements faced in

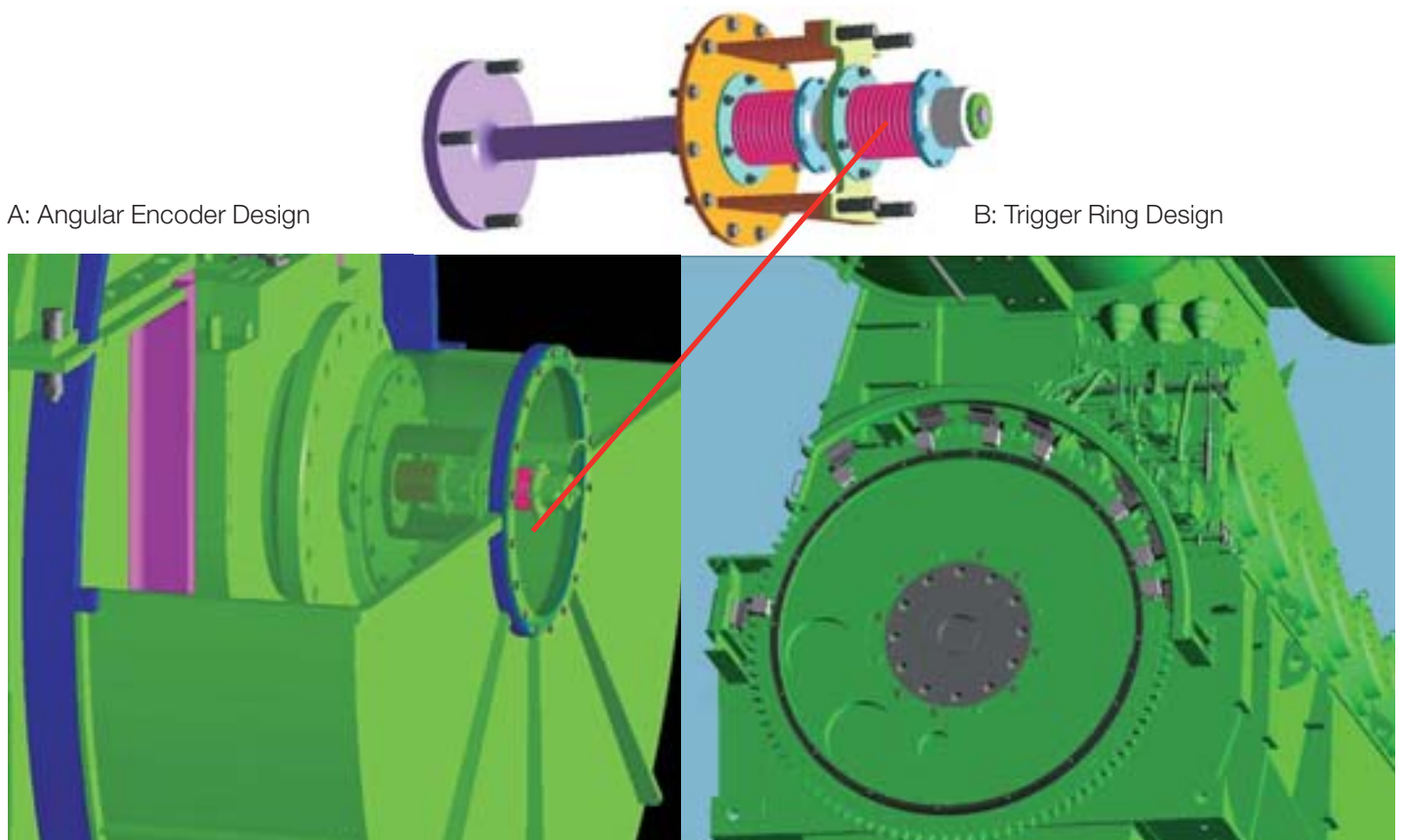

Fig. 37: Tacho system, angular encoder design

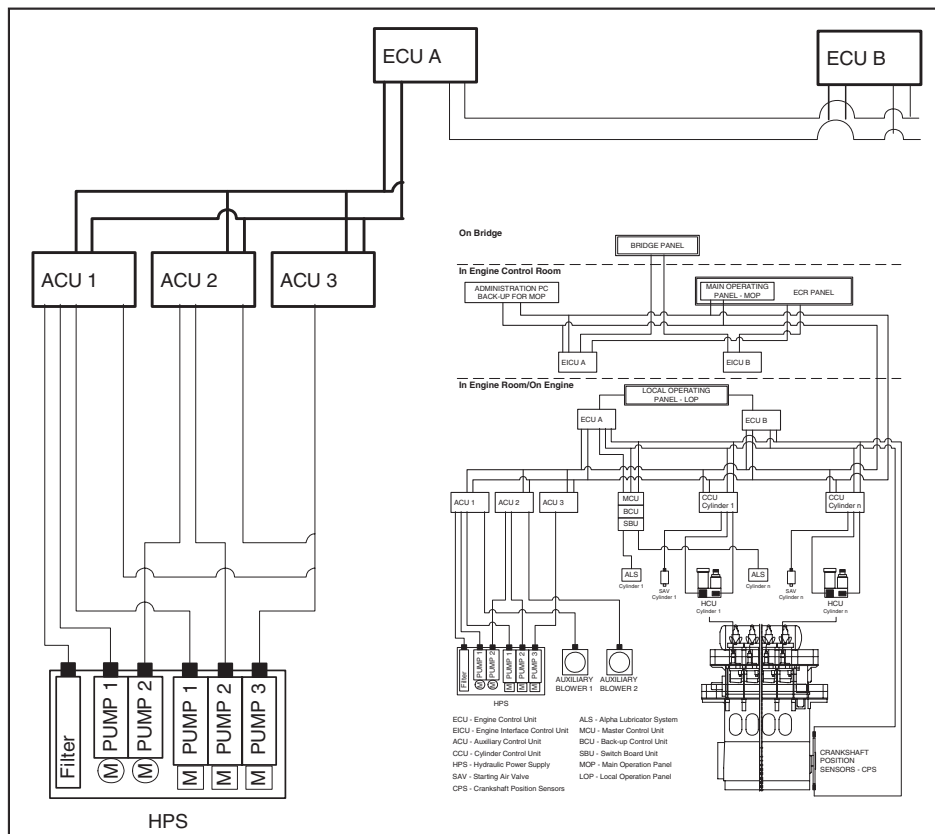

Fig. 38: ME-system, control diagram (initial version)

relation to arrangement and installation. For instance, the display can either be mounted in the control room console or alternatively in an optional cabinet (bracket) for use as a desk top type.

The new configuration will, as a consequence, only use the 24V supply. In this way, the 110V Uninterrupted Power Supply (UPS) can be omitted.

Network

Vessels in service have experienced alarms concerning failure in the communication between the individual MPCs due to momentarily overload of the network. The overload has not affected the operation of the engine because of the redundancy of the system. An updated software version has solved the problem.

Alarm status

One area of concern has been the too many and often less relevant alarms. The original ME control software has had a large number of less relevant alarms. In many cases, the alarms only had minor importance for the engine running condition, and the operating crews could not do anything to rectify. Control programmes and software have been upgraded and modified to root out less relevant information.

Tacho system

Initially, the ME tacho system was designed on the basis of trigger segments with a sine-curved tooth profile mounted on the turning wheel. The total trigger ring was built from eight equal segments. Two redundant sets of sensors were applied. This initial tacho system is relatively expensive, and the system

is also rather time consuming to commission on test bed/sea trials. Today, this system is only specified if the free end of the crankshaft is occupied by other equipment like power take-offs.

The new tacho system is based on optical angular encoders installed on the free end of the crankshaft. This system, consisting of two redundant encoders, is easier to install and adjust. Fig. 37 shows the two systems.

When properly adjusted, both tacho systems have, in general, given rise to only minor concern. However, one event where an incorrectly installed (tightened) Geislinger damper fell off the crankshafts has been experienced. This caused damage to both angular encoders, and at the same time resulting in 'loss of manoeuvrability'.

ME system documentation

In one incident, 'loss of manoeuvrability' was partly caused by a lack of precise documentation/information. This has been rectified by updating both our instruction book and by introducing two additional alarms.

In order to be able to understand the incident it is necessary to know the principle of redundancy applied in the ME system. This principle of redundancy dictates that no single failure must stop the engine or prevent further propulsion. However, the consequence of more failures is undefined. This principle is fully accepted by the classification societies.

The incident occurred on an ME engine with four (4) engine-driven hydraulic pumps. Control of one of these pumps was lost. When this happened, the swash plate for the uncontrolled pump went to 'full ahead'. In the original version of the instruction book, a system consisting of only three (3) engine-driven pumps is shown, Fig. 38. Each of

Additionally, steel spacers have been fitted below the return spring to remove the turning effect created from compression of the spring and hereby affecting the alignment of the small plungers.

In the event of a low engine room temperature, it may be difficult to keep the cylinder oil temperature at 45°C in the ME Alpha Lubricator mounted on the hydraulic cylinder unit.

Therefore, we have introduced insulation and electrical heating of the cylinder oil pipe from the small tank in the vessel and of the main cylinder oil pipe on the engine.

ME engine service experience – summary

The comments presented in this paper are all based on actual feedback experience from owners and ship crews.

All issues are addressed continuously as they occur, so as to control and eliminate teething troubles immediately.

Some of the very positive feedback that we have received, by way of statements received from operating crews, are summarised below in bullet points:

- Engines of this type allow a considerable saving of fuel and cylinder oil
- The electronic control system of the engine allows supervising of practically all operating processes, such as: lubricator management, cylinder oil consumption control, load distribution on cylinders, cylinder cut-off in the event of a malfunction without stoppage of the main engine
- A considerably smaller amount of fuel deposits from combustion in the scavenge air boxes and the exhaust gas economiser is observed

- The system provides wider options for adjustment of the engine
- In spite of its complexity, the system is divided by several standard modules, thereby, allowing the crew to quickly locate a faulty module
- No special periodic maintenance is required for the electronic parts
- The modules' design allows easy and rapid replacement
- The modules and control units of the system have a built-in central processing unit (CPU) that ensures continuous self-monitoring of the technical condition, and an alarm is given to the crew in the event of any abnormalities
- The communication between the operators at the three remote control stations, i.e. the bridge, the starboard wing, and the engine control room, and the control units of the system is effected by means of a special industrial network that reduces the number of wires needed for data transferring, i.e. reliability is improved.

We take this as a proof of the ME engines gaining momentum in the market and most certainly presenting operating advantages to owners and crews.

The MC/MC-C Engine Series

Time Between Overhaul for the latest generation of MC engines

Over the last 4-5 years, the Time Between Overhauls (TBO) has been gradually extended in our written material describing typical obtainable TBOs, Fig. 40.

This development has triggered the wish to extend TBOs further, and for certain ship types (e.g. VLCCs), it has prompted investigation into whether 32,000 hours (or 5 years) between overhauls are realistic.

As the basis for the investigation, we have chosen the S90MC-C/ME-C engine series as a representative for the newest generation of MC engines. This engine series has been designed and delivered with the newest features available for the MC/ME engines:

- OROS combustion chamber with high topland piston
- Cylinder liner with optimised liner wall temperature
- Alu-coated piston rings, Controlled Pressure Relieve (CPR) top ring
- Alpha Lubricator in ACC mode (0.19 g/bhphXS%)
- Exhaust valve: Nimonic spindles and W-seat bottom piece
- Slide fuel valves

Approximately 40 vessels, Fig. 41, with 6S90MC-C/ME-C engines have been used to back-up the claim that TBOs of 32,000 hours (or 5 years) is a realistic option.

On the vessel *M/T Maria Angelicousis* (equipped with a Hyundai-built

TBO S90MC-C/ME-C			
Overhaul guiding interval (Hours)			
Component	Old MC-C	New MC-C	ME-C
Piston rings	12-16,000	16,000	24,000
Piston crown	12-16,000	16,000	24,000
Piston crown, rechroming	24,000	24,000	24,000
Exhaust valve, spindle and bottom piece	16,000	16,000	16,000
Fuel valve	8,000 (nozzle) 8,000 (spindle guide)	8,000 (nozzle) 16,000 (spindle guide)	8,000 (nozzle) 16,000 (spindle guide)
Fuel pump	16,000	32,000	-
Fuel pressure booster	-	-	48,000

Fig. 40: Time Between Overhaul (TBO), guiding intervals

6S90MC-C engine), piston overhauls have been carried out successively from 8,000 hours and upward, see Fig. 42. The piston ring wear is extremely low, and from this point of view indicates 'infinite lifetime'.

The vessels *M/T Kos* and *M/T Astro Cygnus* are also both equipped with Hyundai-built 6S90MC-C engines. In these engines, the pistons have been pulled between 20,000-21,000 hours and 22,000-24,000 hours, respectively. The pulling of pistons on both these engines was caused by 'internal coking' of the pistons. The reason for this was fuel oil contamination of the system oil,

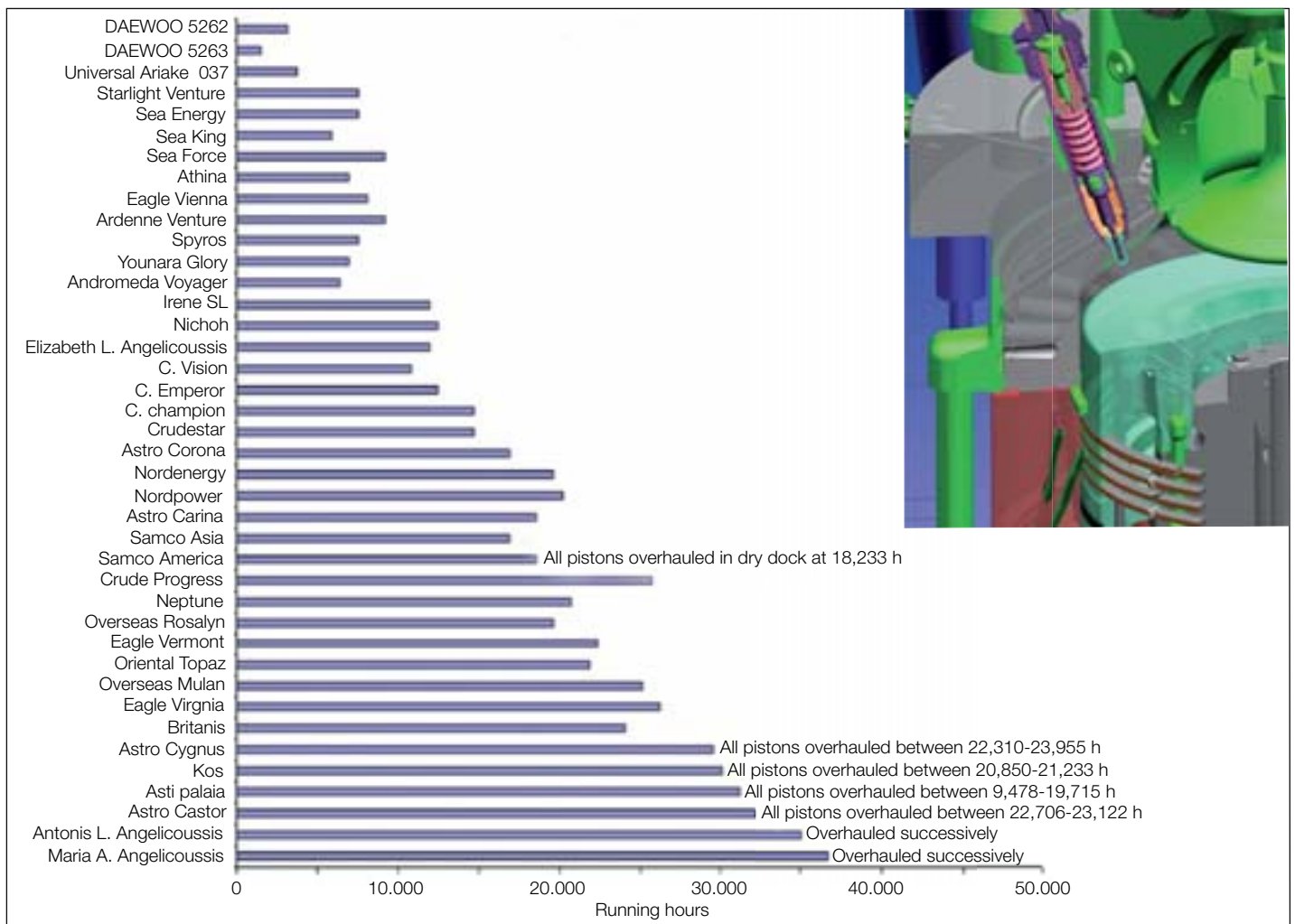

Fig. 41: Fleet of VLCCs equipped with 6S90ME-C/MC-C

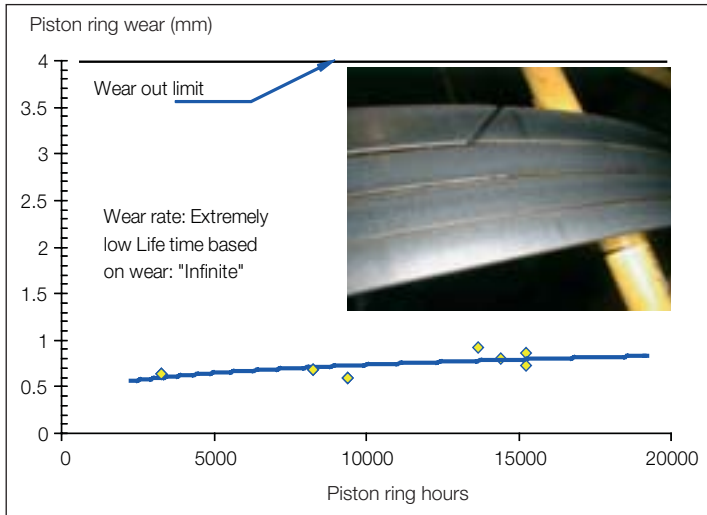

Fig. 42: Piston ring wear measurements, prototype 6S90MC-C (M/T Maria A. Angelicoussis)

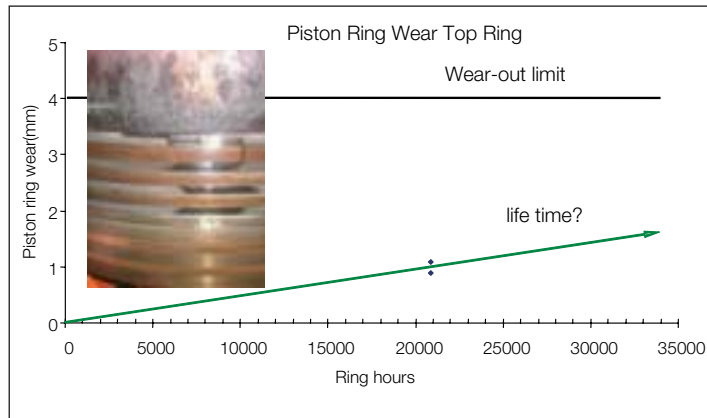

Fig. 43: Piston ring wear measurements, 6S90MC-C (M/T Kos)

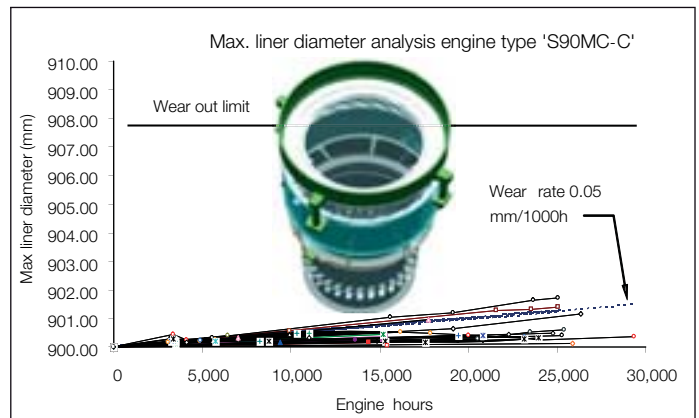

Fig. 45: 6S90MC-C, cylinder liner wear

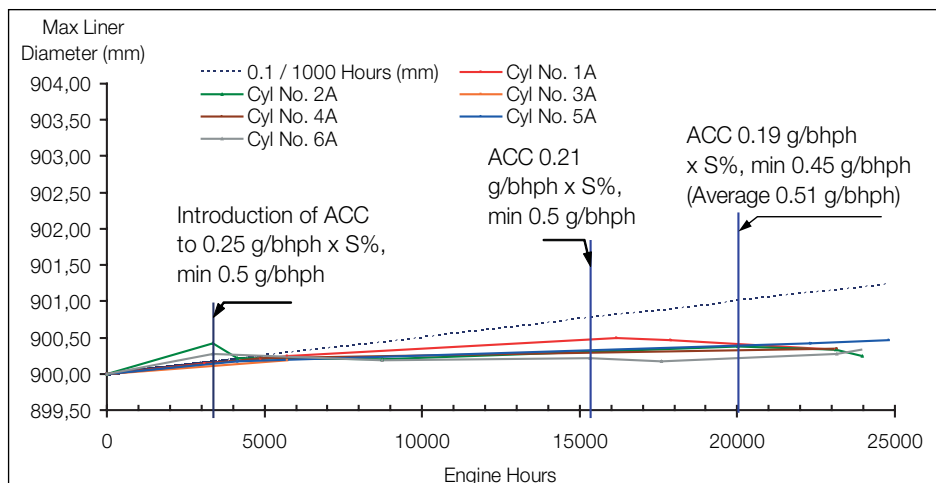

Fig. 44: Cylinder liner wear, cylinder oil reduction test, 6S90MC-C (M/T Astro Cygnus)

in both cases caused by leaking fuel pumps. Apart from this specific problem, both engines have shown excellent cylinder condition with low piston ring wear rates, Fig. 43.

The engine onboard *M/T Astro Cygnus* has been a 'test-vehicle' for the further cylinder oil consumption testing according to the so-called Alpha ACC principle (ACC=Adaptive Cylinder oil Control). As can be seen in Fig. 44, this test has been extremely successful and it indicates further potential for reduction in the cylinder oil consumption.

Below is a summary of the cylinder condition based on all observations on the S90MC-C/ME-C engine:

1. Cylinder liner wear rates: 0.02-0.07 mm/1,000 hours (Fig. 45)
2. Piston ring wear rates: Predicted lifetime: 50,000 hours (Fig. 46)
3. Piston ring groove wear rates: Predicted time between reconditioning: 40,000 hours (Fig. 47)

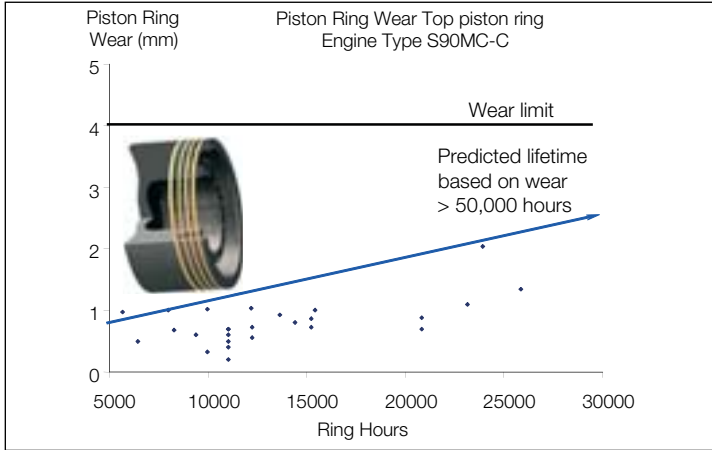

Fig. 46: 6S90MC-C, Piston ring wear

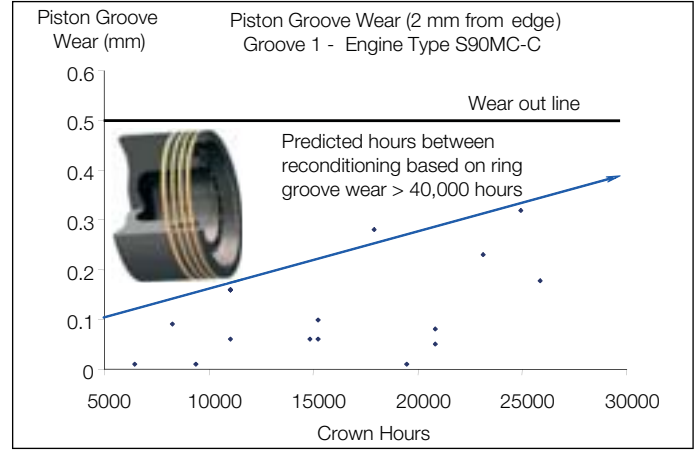

Fig. 47: 6S90MC-C, Piston ring groove wear

K90MC, W-seat and nimonic spindle at 36,400 hours without overhaul

The exhaust valve condition also gives rise to optimism with respect to the increase of TBOs. Fig. 48 shows a bottom piece of the W-seat design in combination with a nimonic spindle on a K90MC engine inspected after 36,400 hours without overhaul.



Fig. 48: Nimonic exhaust spindle and W-seat bottom piece

With respect to the fuel equipment, 32,000 hours seem to be realistic for the fuel pump itself. The latest experience with the fuel valves confirms overhaul intervals of 8,000/16,000 hours at which point both the fuel nozzle and the spindle guide should be exchanged. This experience is based on fuel valves of the slide valve type equipped with nozzles of the compound type.

Based on service experience in general, we can conclude that the time between major overhauls of 32,000 hours (or 5 years) is within reach, Fig. 49.

To increase margins further in this respect, we will introduce the following design improvements which are not present on the 6S90MC-C engines described in this section:

TBO S90MC-C/ME-C				
Overhaul guiding interval (Hours)				
Component	Old MC-C	New MC-C	ME-C	Realistic potential
Piston rings	12-16,000	16,000	24,000	32,000
Piston crown	12-16,000	16,000	24,000	32,000
Piston crown, rechroming	24,000	24,000	24,000	32,000
Exhaust valve, spindle and bottom piece	16,000	16,000	16,000	32,000
Fuel valve	8,000 (nozzle) 8,000 (spindle guide)	8,000 (nozzle) 16,000 (spindle guide)	8,000 (nozzle) 16,000 (spindle guide)	8,000 (nozzle) 16,000 (spindle guide)
Fuel pump	16,000	32,000	-	32,000
Fuel pressure booster	-	-	48,000	48,000

Fig. 49: TBO: 32,000 hours realistic potential

- Increased scuffing margin: modified piston ring package, Fig. 50

For tanker operators, these higher TBOs mean that major overhauls can be done in connection with the scheduled dry dockings of the vessels.

that in this engine, unit No. 1 has still not been overhauled after more than 41,000 hours of operation.

- Anti internal coking device: piston cooling insert, Fig. 51

For container carrier operators another, more condition-based philosophy, will pay off. Such philosophy is practised on the K98MC prototype engine on board *M/V Antwerpen Express*. Fig. 52 shows

As a conclusion, we can support the wish to extend TBOs further, and for certain ship types (e.g. VLCCs) up to 32,000 hours (or 5 years) between overhauls are realistic, Fig. 49

- Ring groove wear reduction: underside chrome plating on rings 1 and 2, Fig. 50

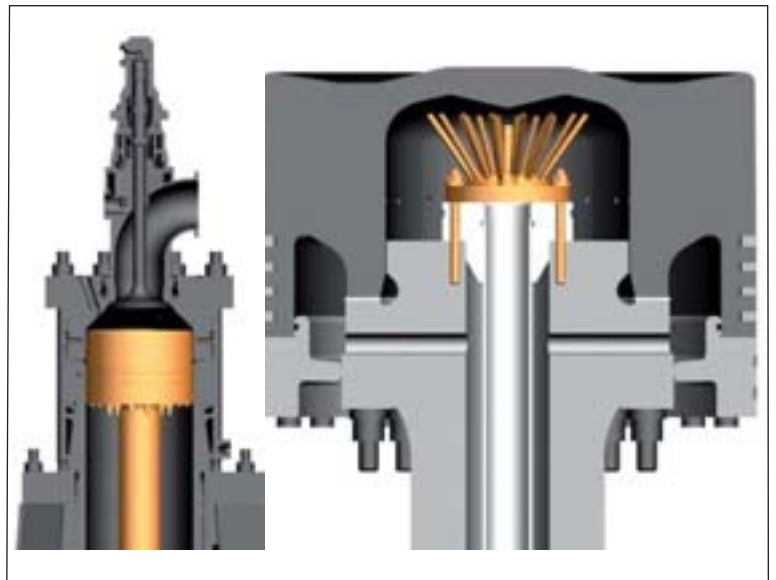
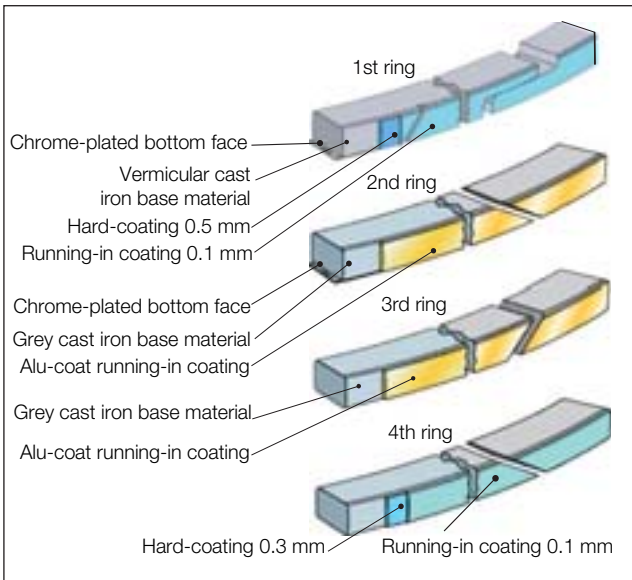

Fig. 50: Updated piston ring package (rings 1&2 Cr-plated undersides)

Fig. 51: Piston cooling insert

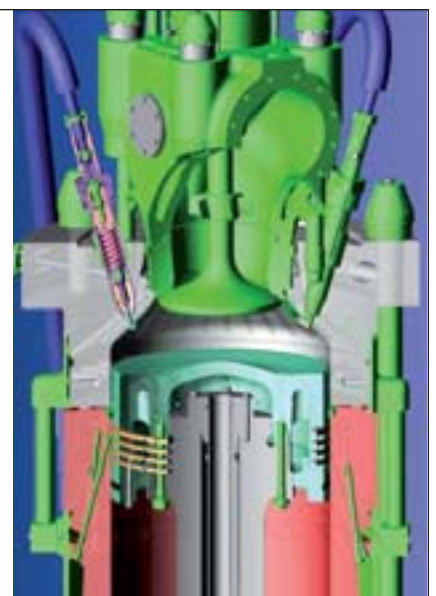
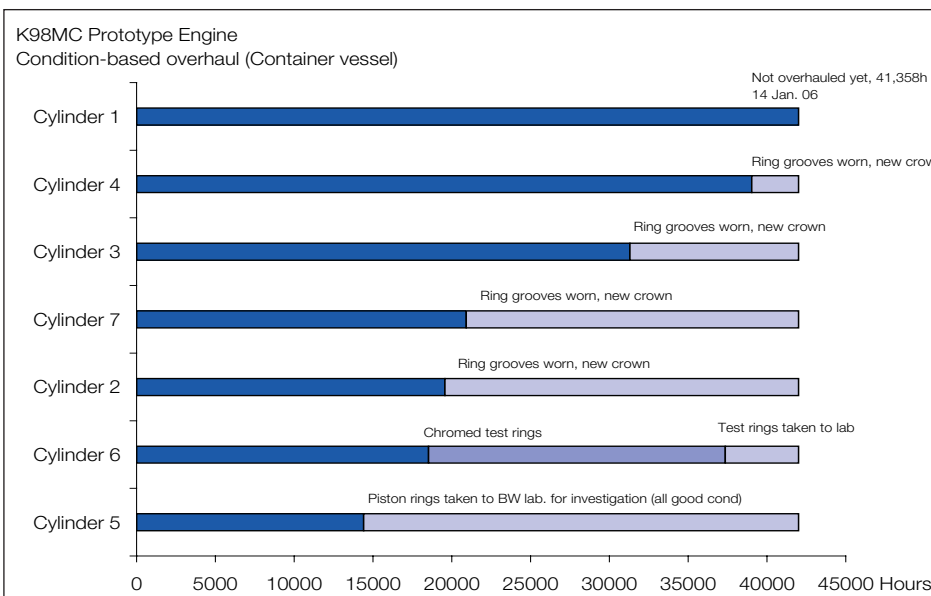

Fig. 52: 7K98MC, condition-based overhaul

Scuffing investigation

Scuffing of cylinder liners has become a recurring incident on some K98 and K90 engines. Other engine types have also been affected, but to a much lesser degree. Some of the cases have been related to traditional service disturbances like production mistakes and poor fuel cleaning. However, other cases remain unexplained.

Several design updates of the ring package have reduced, but not eliminated, the cases.

Data logging

One big issue in the cases has been the lack of accurate and comprehensive information of the engine performance at the time of the scuffing start. The unpredictable pattern of scuffing necessitates continuous measuring and recording of data. In the event of scuffing, it is then possible to go back in time and analyse the engine condition at the start of the scuffing.

However, the actual start time may be difficult to establish. A fully developed state of scuffing will give indications on the jacket cooling water and the exhaust gas temperatures, but it may take days before the condition is serious enough to give clear signals. Unfortunately, at this stage the liner is beyond recovery.

The widely used 'liner wall temperature monitor', based on two temperature sensors in the upper end of the liner, one to port and one to starboard side, is a useful instrument, which can detect scuffing in the early stages.

Thanks to the good cooperation with the owners, we have installed a data logger in *M/V CMA CGM Verdi* (10K98MC-C), a large container liner trading between China and Europe. The Samsung automation system can display all engine parameters in the control room, but only the alarms are



Fig. 53: Piston ring with 'white layer'

logged. Our data logger receives engine parameters, including the signals from the liner wall monitor, from the automation system and stores them every 30 seconds. The logger memory has a capacity for more than six months' service.

Scuffing

The consequences of scuffing have been well-known for a very long time – the piston ring surfaces, Fig. 53, become rough and hard (cementite), the liner surface is corrupted in several ways and the liner wear rate is astronomical, 10 mm/1000 service hours has been recorded. It is also known that if we want to provoke scuffing in an experimental engine, the effective method is to inject water through the scavenge ports. Because of the condi-

tions above, the identification of the causes of service scuffing is difficult. However, water ingress, sudden big power changes and over-lubrication are main candidates to which there are straightforward countermeasures.

Designwise, the objective is to increase the resistance of mainly the piston ring package. Lately, success has been achieved by coating of the surfaces with high grade materials, Fig. 50.

Water ingress

Under tropical conditions, large quantities of condensate water can be formed in the charge air cooler. To facilitate drain of this water, a reversing chamber is arranged below the air cooler, containing a water mist catcher, and the water is drained by a number of pipes, Fig. 54. To our knowledge, this arrangement is effective, but because water ingress is one of the scuffing reasons, the amount of water drain must be included in the measurements. We have arranged a set of measuring tanks with the purpose of separating the water from the airflow in the drain pipes.

Sudden, big load changes

This happens when a ship leaves a port and accelerates to full speed. The power increase is controlled by the governor, which has built-in torque and load limit-

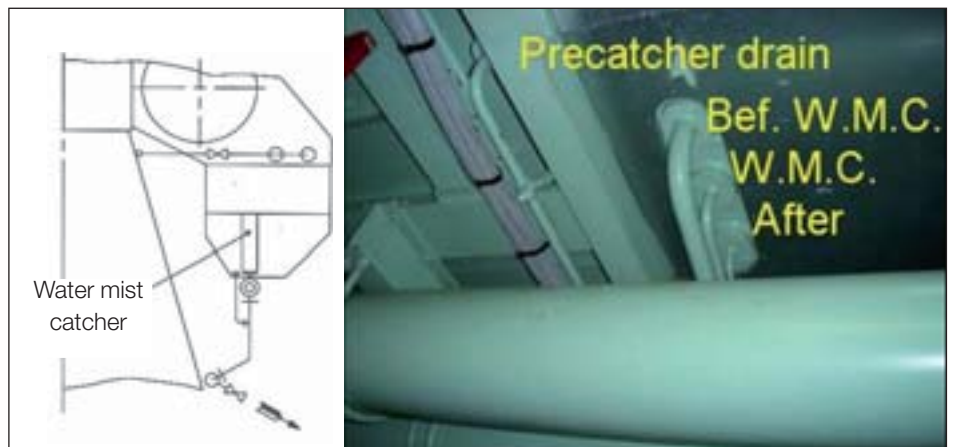

Fig. 54: Drain pipes from charge air coolers

ers. The limiters reduce the rate of power change to the recommended values. The data logger records the load change, and should a case of scuffing start shortly thereafter, we have a possible cause.

Over-lubrication

Besides the waste of valuable lube oil, over-lubrication of the liners has at least two negative effects: bore polish, a condition produced by a state of 'no wear, no corrosion', and build-up of heavy deposits on the side of the piston, which may disturb the oil film in the liner. We have issued Service Letters (SL385, SL417, SL455), which provide guidance. Furthermore, we have introduced the computer-controlled Alpha Lubricator, which makes it very easy to follow the guidance. Presently, the data logger cannot record the feed rate of the cylinder lubrication.

First results

The data logger installation, including the measuring tanks for cooler casing drains, see Fig. 55, was completed on 1 November 2005 in Hamburg, and the log started on 4 November 2005. For

practical reasons, only cylinder units 7 and 8 parameters were recorded. By chance, cylinder unit 8 had the latest ring package installed at the same time as part of a general upgrading. The package had hard-coated ring Nos. 1 and 4, see Fig. 50. Cylinder unit 8 is adjacent to the charge air inlet box with the flap valves – if water is carried over, it will hit cylinder unit 8, Fig. 56.

Running-in of cylinder unit 8 rings was recorded. A couple of weeks' recordings showed elevated and unstable liner temperatures, Fig. 57. The alu-coat ring package will seal up much quicker in a cylinder unit. No drain was recorded until the Indian Ocean, where the seawater reached 30°C. During the passage from Jeddah to Port Klang, three periods with drain were recorded. It should be noted that there is no drain from the volume after the water mist catcher. Nevertheless, each of the three incidents gave elevated liner temperatures, the last one above the alarm limit of 150 degrees. Because of the alarm, the chief engineer increased the lube oil dosage by 50% in cylinder

unit 8 and in the last hours before Port Klang, the liner temperature was stabilised as a result. In Port Klang, the rings of cylinder unit 8 were photographed through the scavenge port and minor damage to the hard-coat could be seen, see Fig. 58. Later records showed a stable cylinder unit 8.

Sub-conclusion on first results

The Port Klang incident is the first documented case of a scuffing recovery. The experience with plain cast iron rings is that increased lubrication and reduced power in the unit will stabilise the liner temperatures. However, the destruction of rings and liners cannot be avoided.

The records showed that no plain water is passing the water mist catcher, but the situation with drain from the cooler casing is nevertheless dangerous. Further sensor installation will enlighten us with regard to mist carry-over, Fig. 59



Fig. 55: Measuring tanks for cooler casing drains



Fig. 56: Cylinder unit 8 adjacent to the charge air inlet box

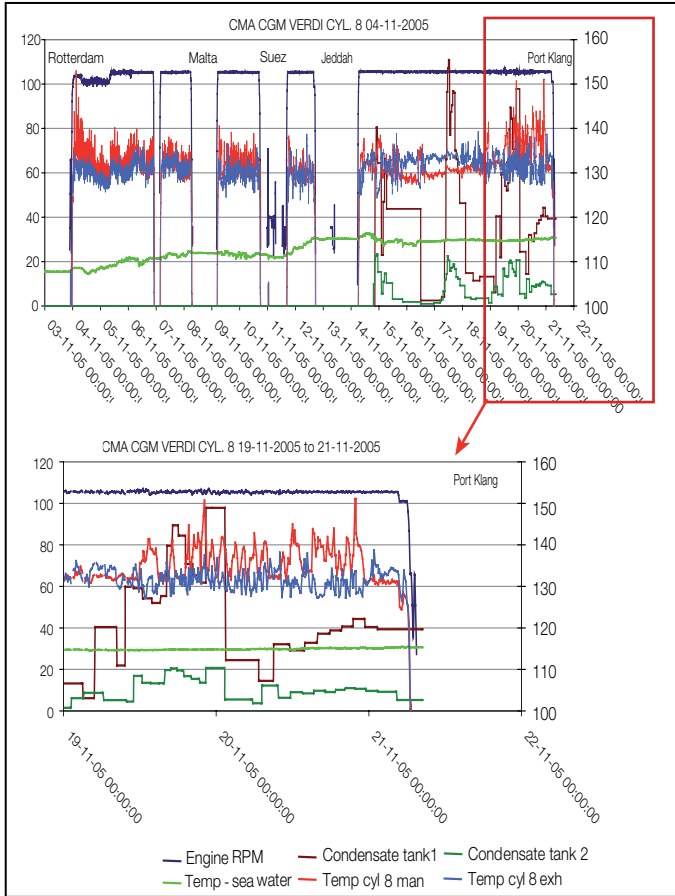

Fig. 57: Log data from first voyage



Fig. 59: Water mist sensor



Fig. 58: Cylinder unit 8 rings, Port Klang



Bearings

Since the last Meeting of Licensees in 2002, the positive development with respect to main bearing damage has continued. Despite the heavy increase in the number of main bearings on MC/MC-C engines, the number of reported damage remains at a constant low level, Fig. 60.

For AlSn40 crosshead bearings, we have had a number of reports (nine (9) altogether) where overlay corrosion

has been found. In most cases, this has taken place on bearings where an interlayer of nickel has been exposed. It is well-known that the nickel has bad tribological properties and that a risk of scuffing between the bearing shell and crosshead pin is present, Fig. 61

In all cases of overlay corrosion, excessive water in the system oil has been detected. If the oil system becomes contaminated with an amount of water

exceeding our limit of 0.2% (0.5% for short periods), corrosion may start. A water content higher than 1% could lead to critical damage within few days of operation. A service letter has been sent out in order to inform (reinforce) about this phenomenon. In this service letter, the lead content level in the system oil has also been devised as an early method of detecting overlay corrosion of crosshead bearings, Fig. 62.

The following values for the **lead content** in the oil system can be used as a guideline:

0-4 ppm lead:
normal

5-10 ppm lead:
Inspect filters & crankcase for bearing debris, prepare inspection of crosshead bearings when convenient

>10 ppm lead:
Inspect filters & crankcase for bearing debris, prepare inspection of crosshead bearings as soon as possible

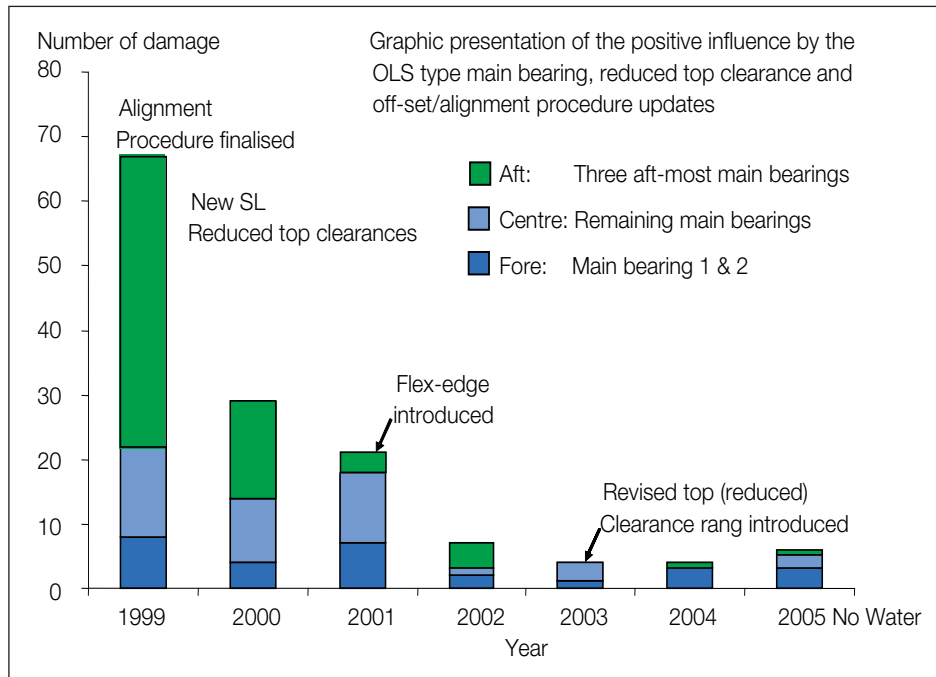

Fig. 60: Main bearing damage statistic

Fig. 62: System oil lead content guideline

New bearing monitoring tools with on-line indication of wear on bearings and an online/offline oil monitoring system are discussed in another paper at this Meeting of Licensees.

Service tests for crosshead bearings with new synthetic coatings based on polymer, molybdenum disulphide/graphite are ongoing and showing good results, Fig. 63. This technology can be spread to other bearings than crosshead bearings where static friction is a limiting factor.

Cracks in the camshaft housing on K98 engines

Cracks in the camshaft housing for a number of K98MC-C engines have been detected over the last six months. At the time of writing, six (6) engines have been affected. In all cases but one, the cracks were found in the camshaft bearing pedestal No. 1. Analyses have shown that bearing pedestal No. 1 is approx. 30% more loaded than other camshaft housing bearing pedestals, Fig. 64.



Partially corroded overlay, not yet scuffed

Overlay completely corroded, away, Ni 100% exposed, partial scuffing between Ni-layer and pin

Overlay completely corroded, away, partly scuffing between Ni-layer and pin, partly steel-to-steel

Fig. 61: Crosshead bearing overlay corrosion

Crosshead bearing after 2500 rh. Good condition



Fig. 63: Synthetic overlay on AlSn40 crosshead bearing shell



Fig. 66: Crack in camshaft bearing pedestal

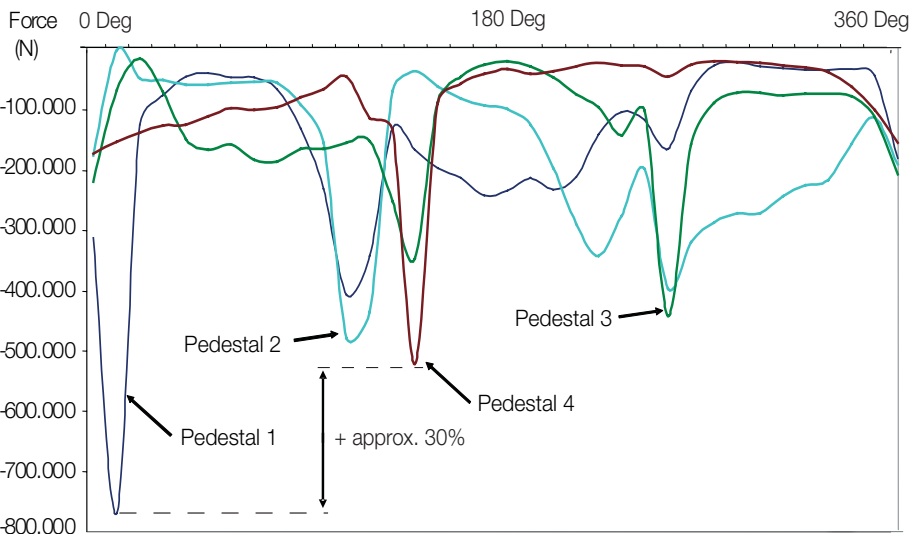

Fig. 64: Camshaft bearing pedestal loads

Fig. 65 outlines on a drawing where the crack path is. An example of crack detection can be seen in Fig. 66. At the time of writing, 90 engines have been checked and we intend to inspect all engines in order to know the precise extent of the problem.

A number of countermeasures/rectifications have been developed in order to repair engines with cracks. Furthermore, preventive countermeasures have been developed. In this relation it is important to distinguish between the

two (2) different designs for camshaft housings on the K98 engines, Fig. 67:

- A. An integrated camshaft housing where the cylinder frame and camshaft housing are cast together
- B. A separate camshaft housing where the camshaft housing is bolted on the cylinder frame

Cracks have been detected in both cases. However, repair methods differ somewhat. The following scenarios have been considered:

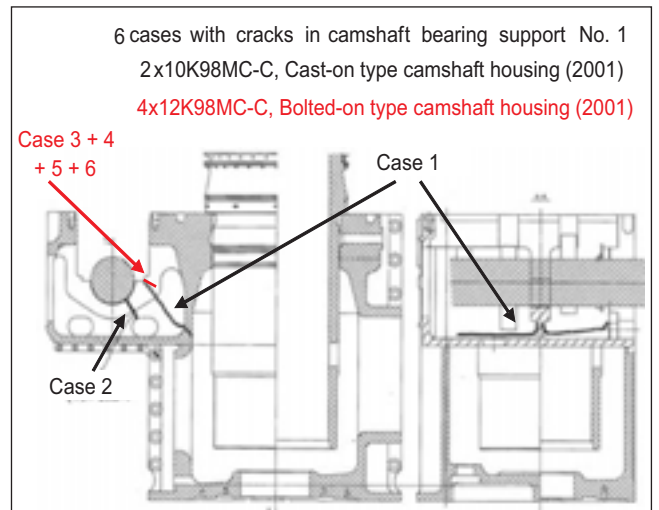

Fig. 65: Crack paths in camshaft bearing pedestals

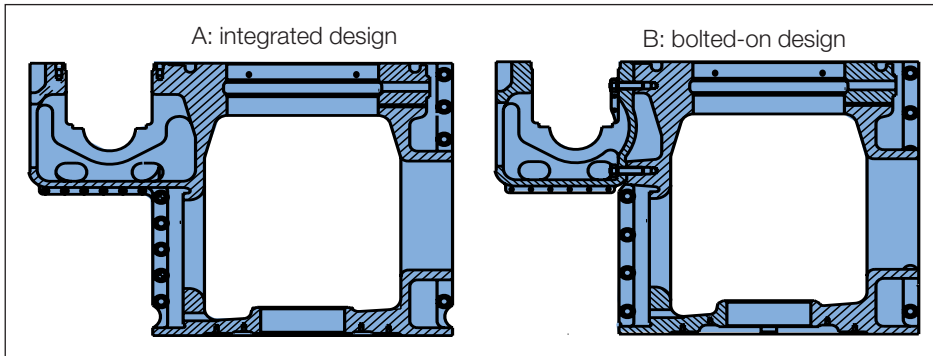

Fig. 67: Cylinder frame camshaft housing design

1. For new engines on which cylinder frames/camshaft housings have not been cast, a design change with more margin for production-related deviations has been made. This design accommodates enlarged roundings and relocation and down-sizing of oil holes closest to the cylinder frame, Fig. 68.
2. For cylinder frames/camshaft housings already cast but not yet machined, a modification to the machining is used to introduce larger roundings. In the oil holes, the requirements to the surface quality are increased according to an updated quality specification. In general, this

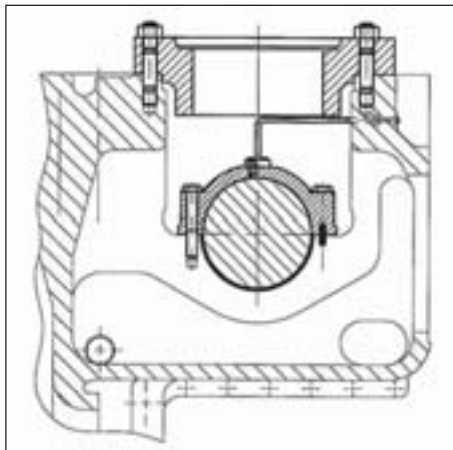

Fig. 68: Updated design of camshaft housing (large roundings and size reduction of oil hole)

modification is specified on all camshaft housing bearing pedestals. However, for engines already assembled and tested or in vessels, 'hand-machining' has been done and in such cases only pedestal No. 1 is modified, Fig. 69.

3. An alternative method of reducing the stress level on bearing pedestal No. 1 is to install a so-called 'hang-



Fig. 69: 'Hand machining' of camshaft housing bearing pedestal roundings

ing bearing No. 0' in front of cylinder No. 1, fuel cam, Fig. 70. This method has been used on a number of newbuildings before ship delivery as an alternative to machining of larger roundings.

4. For engines with cracks propagating in the main cylinder frame structure (Fig. 65, case 1), a new one-cylinder frame block has been prepared. This block will be exchanged when the vessel docks in August 2006.
5. Fig. 65, case 2 shows a crack in a cylinder frame with an integrated camshaft housing. However, the crack has only propagated in the bearing pedestal No. 1 in the camshaft housing. Fig. 71 shows the principle of two hanging bearings installed hanging from cylinder No. 1 base plate. This will completely offload the camshaft bearing pedestal No. 1 when the bearing shell is removed. Installation of this solution

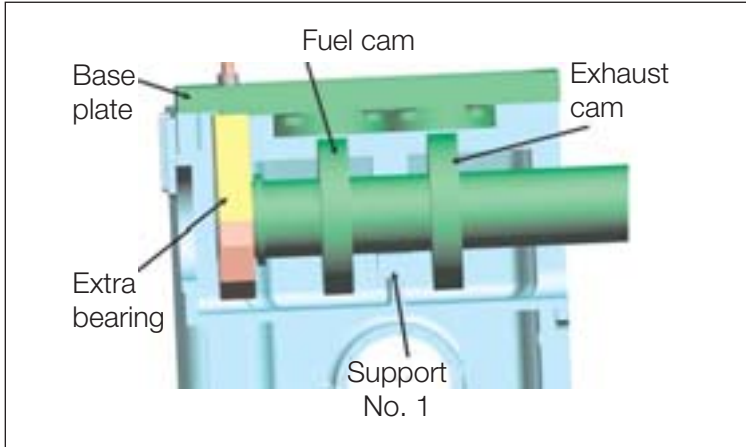

Fig. 70: 'Hanging camshaft bearing No. 0'

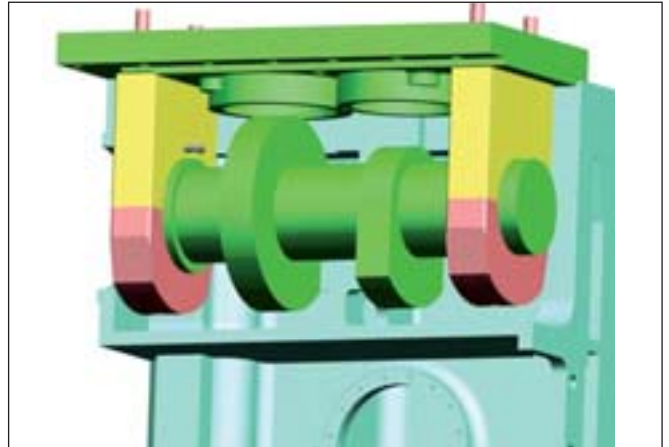

Fig. 71: Repair of cracked bearing support, 'two hanging camshaft bearings'

will be carried out in cooperation with the owner involved in order not to disturb the operation of the vessel.

6. Exchange of two separate cylinder camshaft housing sections are planned on four (4) vessels. Fig. 72 shows the work done on the first vessel on which such operation has been carried out during scheduled docking.

7. In situ machining of larger roundings has been made possible during short port stays by means of a dedicated machine for this purpose, Fig. 73. A number of these machines are now in operation for engines entering dry dock, engines already assembled, and as a preventive measure for bearing pedestal No. 1 on vessels in service.

The above-described items 1-7 cover, at the moment, all our joint efforts to minimise damage made by these cracks. We will continue throughout 2006 to make initiatives in this respect and we will thereby be able to demonstrate effective handling of this case to the benefit of our customers, the ship-owners.

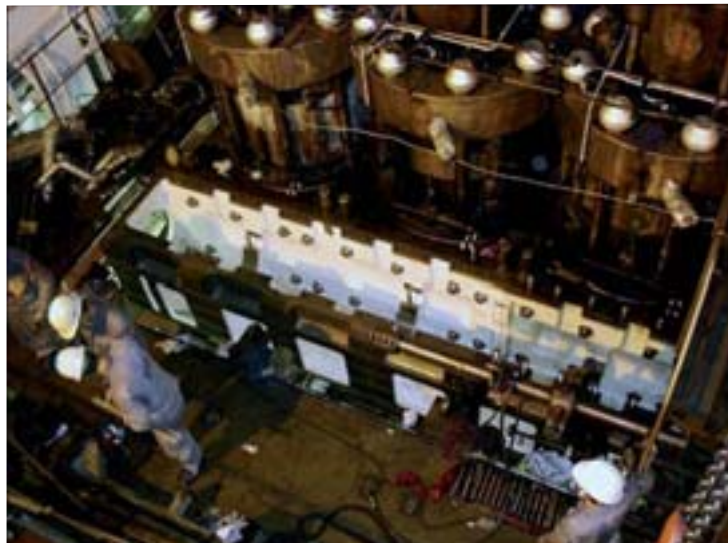

Fig. 72: Exchange of cracked two-cylinder camshaft housing section

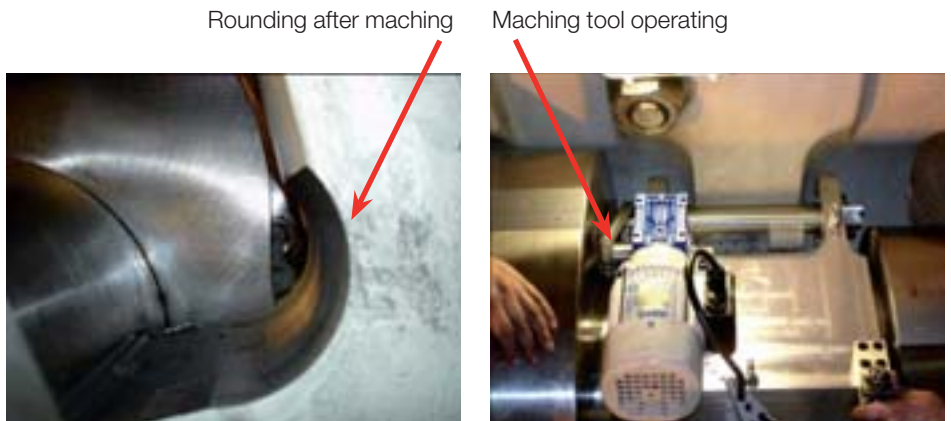

Fig. 73: Machine for 'in situ machining' of roundings

Concluding Remarks

As mentioned, the reference list of ME engines, see Fig. 6, comprises engines right from the L42ME to the K98ME/ME-C, in a fairly even distribution among about 35 owners of tankers, bulkers and container ships.

The ME/ME-C engines have had a successful introduction in the market, and they are well accepted.

As with other products containing new technology, there has been some teething troubles, most of which were eliminated quickly.

The service experience for the traditional range of MC/MC-C engines is characterised by a stable cylinder condition, a stable bearing performance and a general extension of the realistic time between overhauls.

When service-related issues, like the camshaft housing cracks on the K98 engine occur, it is of the utmost importance that the licensees and MAN B&W Diesel react coordinated and efficiently towards our common customers in order to minimise the impact on their businesses due to such issues. The camshaft housing cracking issues have once again demonstrated how efficient our joint efforts can be.